

# Operation & Maintenance

# Broce Broom

## BBA48H

### Skid Steer Broom Attachment



Broce Manufacturing Co. Inc. - 1460 South 2nd Avenue - Dodge City, KS 67801  
(877) 227-8811 - FAX (620) 227-3012 - [parts@brocebroom.com](mailto:parts@brocebroom.com)  
M-F 7:00 AM-6:00 PM CST

**1-866-283-2759**

March 2024

[www.brocebroom.com](http://www.brocebroom.com)



**Broce Manufacturing Company, Inc.  
WARRANTY REGISTRATION**

**Purchased From (Dealership)**

Company: \_\_\_\_\_  
Address: \_\_\_\_\_  
City: \_\_\_\_\_ State: \_\_\_\_ ZIP: \_\_\_\_\_  
Delivery Date to Dealer: \_\_\_\_ / \_\_\_\_ / \_\_\_\_ Unit Hours: \_\_\_\_\_  
Model Number: \_\_\_\_\_ Serial Number: \_\_\_\_\_

**Purchaser**

Company: \_\_\_\_\_  
Address: \_\_\_\_\_  
City: \_\_\_\_\_ State: \_\_\_\_ ZIP: \_\_\_\_\_  
Delivery Date to Dealer: \_\_\_\_ / \_\_\_\_ / \_\_\_\_ Unit Hours: \_\_\_\_\_

<b>Purchaser - Type of Business</b>			
Construction/Highway	Rental	Asphalt Contractor	
Equipment Dealer	Municipality	Other	

1. *The Purchaser has been instructed and/or has read the manual and understands proper preventive maintenance, operation and safety precautions.*
2. *The Warranty and Limitations of Liability are found in the Warranty pages enclosed in the Parts and Operators Manuals.*
3. *Broce Manufacturing Co. Inc. reserves the right to make design changes or modifications to Broce products at any time without incurring any obligation to make similar changes or modifications to previously sold units.*
4. *If this Document is not signed and returned to Broce Manufacturing Co. Inc., the warranty begins at the date of delivery to the Dealership.*

**I hereby acknowledge acceptance of above and conditions in the Warranty Policy**

Purchaser/Owner: \_\_\_\_\_

Dealer Representative: \_\_\_\_\_

**Broce Manufacturing Co. Inc.**  
1460 South 2nd Avenue  
Dodge City, KS 67801  
(877) 227-8811



**BROCE MANUFACTURING COMPANY**  
**BROCE BROOM LIMITED TWELVE-MONTH WARRANTY**

For a period of twelve (12) months or 1,000 hours whichever comes first, from the date of delivery of product to the original user, Broce Manufacturing of Dodge City, Kansas warrants each product to be free from manufacturing defects, subject to the limitations contained in this policy. This limited warranty covers parts and labor.

No alterations may be made to attachment without the expressed written consent of Broce Manufacturing company, as this could cause serious injury or death and will also void the warranty.

This warranty does not apply to defect caused, in whole or in part, by unreasonable use while in the possession of the user, including, but not limited to, failure to properly set up product, failure to provide reasonable and necessary maintenance, normal wear, routine tune ups or adjustments, improper handling, accidents, operation at speed or load conditions contrary to published specifications, improper or insufficient lubrication, or improper storage. This warranty is not a guarantee that the performance of each product will meet the expectations of the purchaser.

Broce Manufacturing shall not be liable for consequential damage of any kind, including, but not limited to: consequential labor costs or transportation charges in connection with the replacement or repair of defective parts, lost time or expense which may have accrued because of said defects. In no event shall Broce Manufacturing's total liability hereunder exceed the product purchase price.

Many components used by Broce Manufacturing are subject to the warranties of their respective manufacturers. These warranties will be considered void if the product is modified or repaired in any way not expressly authorized, or if closed components are disassembled prior to return. Closed components include, but are not limited to gearboxes, hydraulic pumps, motors, cylinders and actuators.

Our obligation under the warranty is expressly limited, at our option, to the replacement or repair at Broce Manufacturing of Dodge City, KS or at a service facility designated by us. We are not responsible for unauthorized repairs or replacements. Any implied or statutory warranties, including any warranty of merchantability or fitness for a particular purpose, are expressly limited to duration of this written warranty. We make no other express warranty. This warranty cannot be extended, broadened, or changed except in writing by an authorized officer of Broce Manufacturing.

**Broce Manufacturing Co. Inc.**  
1460 South 2nd Avenue  
Dodge City, KS 67801  
(877) 227-8811



# TABLE OF CONTENTS

<a href="#">Safety Precautions .....</a>	<a href="#">8-9</a>
<a href="#">Attachment Specs .....</a>	<a href="#">10</a>
<a href="#">Serial Number Location .....</a>	<a href="#">11</a>
<a href="#">Attachment Operation.....</a>	<a href="#">12</a>
<a href="#">Connect Electrical System.....</a>	<a href="#">13</a>
<a href="#">Remote Brush Controll .....</a>	<a href="#">14</a>

## **Maintenance**

<a href="#">Lubrication .....</a>	<a href="#">15</a>
<a href="#">Broom Wafer Replacement.....</a>	<a href="#">16</a>
<a href="#">Broom Core Install .....</a>	<a href="#">17</a>
<a href="#">Motor Replacement.....</a>	<a href="#">18</a>
<a href="#">Idler Bearing Replacement .....</a>	<a href="#">19</a>
<a href="#">Water System.....</a>	<a href="#">20</a>
<a href="#">Troubleshooting .....</a>	<a href="#">21</a>

## **Parts**

<a href="#">Full Assembly .....</a>	<a href="#">23</a>
<a href="#">Cover Assembly .....</a>	<a href="#">24</a>
<a href="#">Pivot Assembly.....</a>	<a href="#">25</a>
<a href="#">Broom Core Assembly .....</a>	<a href="#">26</a>
<a href="#">Electrical .....</a>	<a href="#">27</a>
<a href="#">Hydraulic Diagram .....</a>	<a href="#">28</a>
<a href="#">Valve Breakdown .....</a>	<a href="#">29</a>
<a href="#">Decals .....</a>	<a href="#">30-31</a>

<a href="#">Service Parts to Stock .....</a>	<a href="#">32</a>
<a href="#">Notes .....</a>	<a href="#">33</a>



**WARNING:** Cancer  
and Reproductive Harm  
[www.P65Warnings.ca.gov](http://www.P65Warnings.ca.gov)

# DANGER



### MISUSE, OPERATION OR MAINTENANCE BY AN UNAUTHORIZED PERSON COULD LEAD TO SERIOUS INJURY OR DEATH

Operation of this equipment shall be limited to a competent and experienced person. In addition, anyone who will operate or work around this equipment must use good common sense. In order to be qualified, he or she must also know and meet all other requirements, such as:

1. Some regulation specify that no one under the age of 16 may operate power machinery. It is your responsibility to know what these regulations are in your area or situation.
2. Current OSHA regulations state in part: "At the time of initial assignment and at least annually thereafter, the employer shall instruct **EVERY** employee in the safe operation of servicing of all equipment with which the employee is or will be involved."
3. Unqualified person must **STAY OUT** of the work area.
4. A person who has not read and understood all operating and safety instructions is not qualified to operate the machinery.
5. While machine is in operation, there should be no bystanders within 15 to 20 feet of the machine.
6. Absolutely **NO RIDERS** on the attachment.

**FAILURE TO READ THIS MANUAL AND IT'S SAFETY INSTRUCTIONS IS A MISUSE OF THE EQUIPMENT AND WILL VOID FACTORY WARRANTY.**



**WARNING:** Cancer  
and Reproductive Harm  
[www.P65Warnings.ca.gov](http://www.P65Warnings.ca.gov)



# SAFETY PRECAUTIONS

## Entering and Exiting the Operator's Position



Only Enter or Exit the skid steer/loader where proper handholds and steps are available. Inspect the handholds and step for any damage prior to use and perform repairs when necessary. Keep all handholds and steps clean to avoid serious injury.

Maintain 3 contact points with the skid steer/loader and attachment when entering and exiting the operator's position. Face the skid steer/loader when entering and exiting the operator's position. NEVER enter, exit, climb, or jump on a moving or operating attachment.



## Maintenance Shutdown Procedure

**ALWAYS** perform the "Maintenance Shutdown Procedure" **BEFORE** adjusting, lubricating, cleaning, or servicing the attachment. See below for the "Maintenance Shutdown Procedure".

1. Lower the boom arm and rotate the attachment until the bucket contacts the ground and sits flat.

 **WARNING**   
**NEVER** work beneath the attachment  
while boom arms are raised.

2. Apply the parking brake, turn off the skid steer/loader engine, and remove the key from the ignition. **DO NOT** reinsert the key into the ignition until any required maintenance or adjustment is complete.
3. Relieve the pressure in the hydraulic lines by actuating the skid steer/loaders boom controls. NOTE: reference the skid steer/loader's manual for exact pressure relieving methods.
4. Disconnect the attachment's hydraulic lines from the skid steer/loader.

 **WARNING**   
Always wear eye protection, hearing  
protection and dust mask for respiratory irritants.



**WARNING:** Cancer  
and Reproductive Harm  
[www.P65Warnings.ca.gov](http://www.P65Warnings.ca.gov)

# ATTACHMENT SPECIFICATIONS

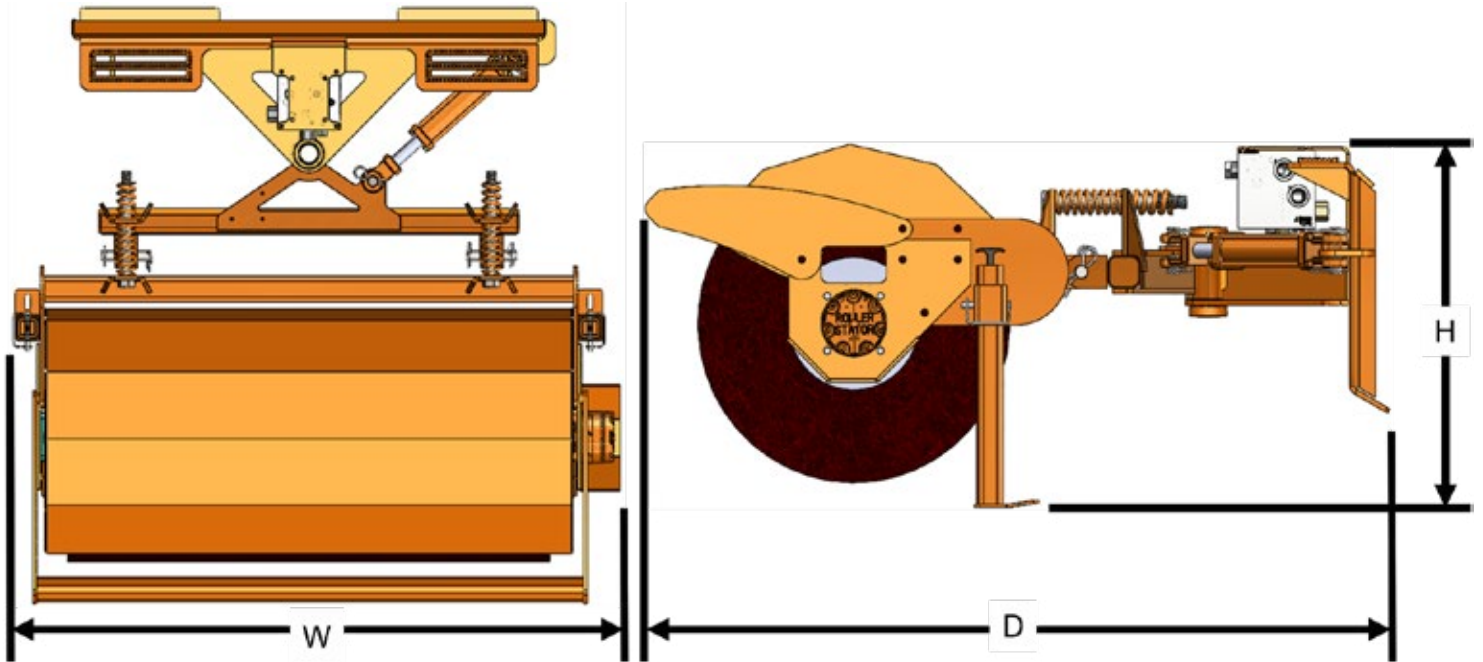

<b>BBA48H</b>	
Brush Width	60"
Overall Width (W)	71"
Overall Depth (D)	58.78"
Standard Package Overall Height (H)	28"
Standard Package Weight (lb <sub>s</sub> )	670 lbs
Wafer Diameter	24"
Input Flow Range	12-30 GPM
Operating Pressure	2500 PSI

 **WARNING:** Cancer and Reproductive Harm  
www.P65Warnings.ca.gov

## SERIAL NUMBER LOCATION

The model/serial number plate is located on the left side of the support arm on the mounting plate. If the model/serial plate cannot be read, the serial number is stamped nearby. See the image below for more details.

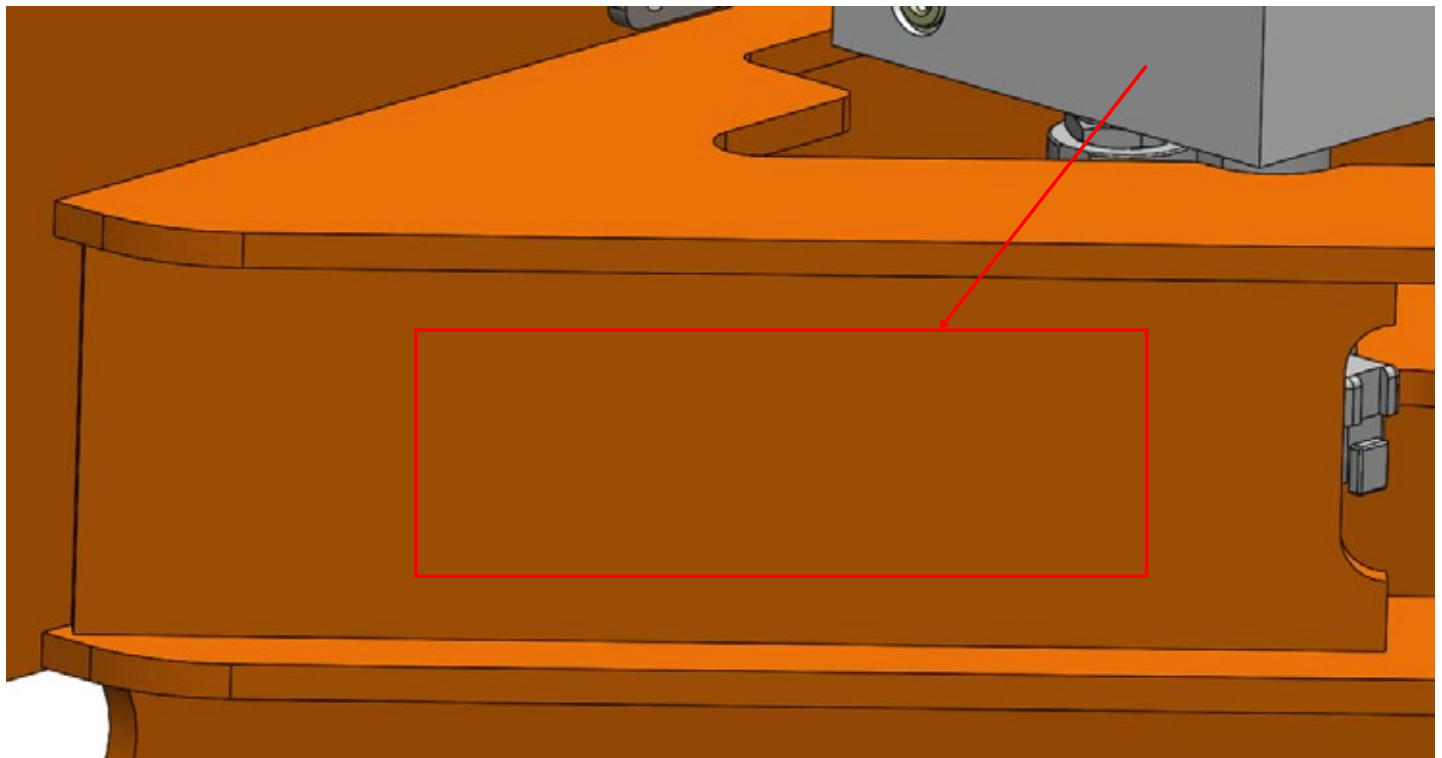

**WARNING:** Cancer  
and Reproductive Harm  
[www.P65Warnings.ca.gov](http://www.P65Warnings.ca.gov)

# ATTACHMENT OPERATION

## **Setup and Pre-use checks**

Before operating the attachment, perform the following “Pre-use Checks.”

1. Ensure all safety decals are legible and free of excessive damage.
2. Check all hydraulic hoses and adapters for leaks and ensure they are tight.
3. Inspect all hydraulic hoses for damage or kinks. Hoses should be free to move during operation and dumping.
4. If the unit has an optional water system, check the wiring and water hose for potential catching or kinking.



## **Coupling the Attachment to a Skid Steer**

1. Start the skid steer/loader engine, retract the attachment pins, and roll the coupler forward.
2. Center the skid steer/loader to the attachment and hook the coupler to the upper attachment strip. Roll the coupler backward and lift the attachment off the ground.
3. Actuate the attachment pins, ensuring the pins are completely engaged. Reference the skid steer/loader operations manual for more detail.

## **Connecting the Hydraulic Couplers**

1. Perform the first three steps of the “Maintenance Shutdown Procedure” found on page 9 before connecting the hydraulic hoses to the skid steer/loader.
2. Inspect the hydraulic couplers for debris or damage prior to connecting the hoses. Clean or replace the couplers if necessary.
3. Press the couplers onto their corresponding couplers on the skid steer/loader. There should be an audible click when properly engaged.
4. Pull on the couplers to ensure they are properly connected.
5. Slowly roll the bucket back to check for interference between the hydraulic couplers and the bucket.
6. If the coupler interferes with the attachment, replace the coupler and straight adapter with the included stubby coupler and 90-degree adapter.



**WARNING:** Cancer  
and Reproductive Harm  
[www.P65Warnings.ca.gov](http://www.P65Warnings.ca.gov)

# CONNECTING THE ELECTRICAL SYSTEM

The Broce Broom Manual Angle Brooms Water System option comes with a plug-and-play electrical system. Perform the following steps to install the electrical system.

1. Select your power method. The attachment includes two (2) different power methods: battery power and cigarette outlet power.
  - **Battery Power:**  
Connect alligator clamps to battery (black to negative and red to positive) and fish power wire into cab of skid steer ensuring cable isn't at risk of snagging or kinking.
  - **Cigarette Outlet Power:**
2. Connect the controller to power.
3. Connect the attachment wire to the controller.



**WARNING:** Cancer and Reproductive Harm  
[www.P65Warnings.ca.gov](http://www.P65Warnings.ca.gov)

## TURNING ON/OFF BRUSH ROTATION VIA THE CONTROLLER

The Broce Broom Hydraulic Angle Brooms allow the operator to actuate the angle control cylinder while the brush is stationary. To turn the brush motor on and off, see the steps below.

1. Ensure all electrical connections are solid. The motor cannot be turned on if the electrical system is not connected correctly.
2. Flip the right-hand toggle switch on the controller to the on position. The switch will illuminate when toggled to the on position.
3. Turn on the auxiliary hydraulics.
4. To turn off the motor, toggle the motor switch to the off position. In this mode, the brush will not spin; however, the angle of the brush can be changed.



**WARNING:** Cancer  
and Reproductive Harm  
[www.P65Warnings.ca.gov](http://www.P65Warnings.ca.gov)

## MAINTENANCE (LUBRICATION)

The attachment has a grease zerk, as shown in the image below.

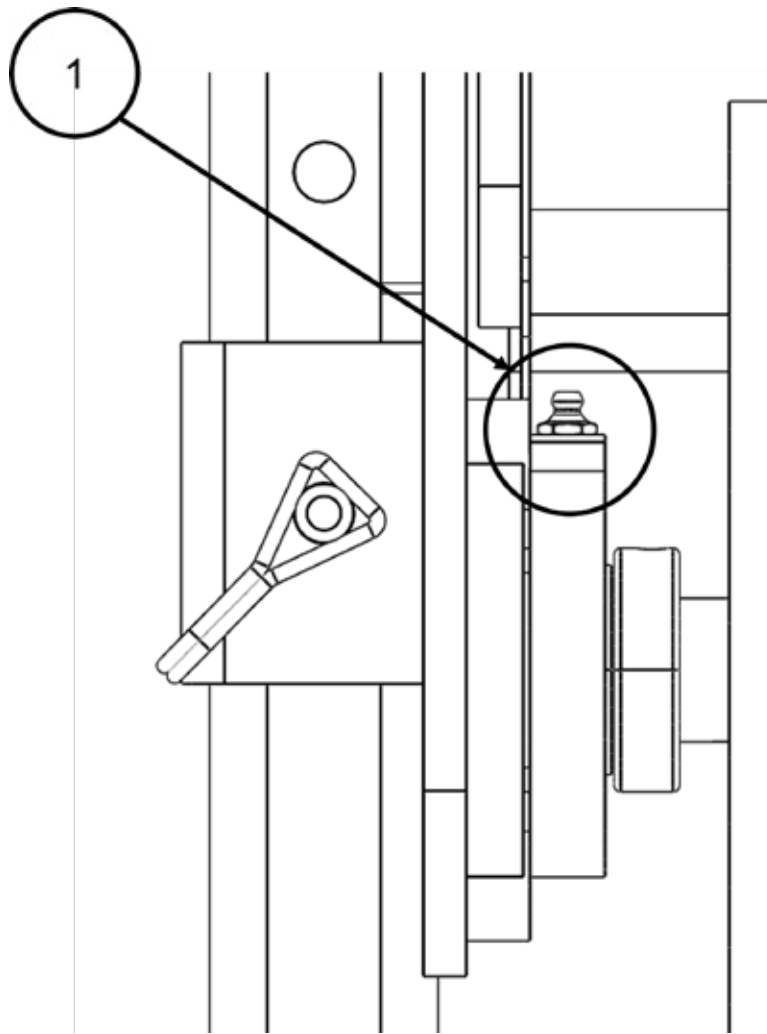

This is a sealed bearing and may require no lubrication throughout its service life. However, no more than two strokes of grease at 200-hour intervals are recommended if lubrication is deemed necessary. Seals are often destroyed by over-greasing sealed bearings. Perform the “Maintenance Shutdown Procedure” found on page 9 before greasing.

**NOTE:** The average grease gun outputs 0.025 - 0.035 ounces per stroke.



**WARNING:** Cancer  
and Reproductive Harm  
[www.P65Warnings.ca.gov](http://www.P65Warnings.ca.gov)

# MAINTENANCE

## (BROOM WAFER REPLACEMENT)

### Wafer Maintenance

The Broce Broom Attachment line uses a 10" x 24" convoluted wafer. See the table below for wafer quantities for 96 inch core.

Core Length (in)	Number of Wafers Required
48	27



### IMPORTANT



Replacement wafer kits can be ordered from Broce Manufacturing at [www.brocebroomparts.com](http://www.brocebroomparts.com) or call 1-580-227-3711.

### Removing the Broom Core

1. Lower the feet to the lowest pin position, then lower the boom arm and rotate the attachment until the feet and lower edge of the attachment plate contact the ground.
2. Perform the "Maintenance Shutdown Procedure" found on page 9.
3. Use an hex wrench to loosen the set screw on the idler-bearing lock ring.
4. Use a punch and hammer to turn the idler-bearing lock ring clockwise until the ring is loose.
5. Remove the two (2) forwardmost bolts from the bumper and loosen the two (2) rear bumper bolts to allow the bumper to hinge up out of the way.
6. Remove the remaining three (3) bolts from the motor mounting plate and put the motor and mount aside. **DO NOT REMOVE THE MOTOR FROM THE MOTOR MOUNT OR DISCONNECT THE HYDRAULIC HOSES FROM THE MOTOR.**
7. Pull the core from the motor side until the core is removed from the bearing. Set the core aside to change the brush wafers. See "Replacing the Brush Wafers" for proper wafer replacement instructions.
8. Remove the remaining three (3) bolts from the idler-bearing mounting plate and set aside for broom core reinstallation.



### IMPORTANT



See page 25 for specific wafer kit ordering information.

### Replacing the Brush Wafers

1. Rotate the broom core onto its motor side end.
2. Remove the 3 bolts holding on the idler assembly and remove the idler.
3. Remove each wafer by sliding them off the core.
4. Before installing new wafers, ensure the broom core is free of damage.
5. Install the wafers one at a time, clocking each 120° offset from the last wafer. A "diamond-shaped" opening should be visible when wafers are properly installed. See the image below for more details.
6. Reinstall the idler assembly.

"Diamond-Shaped Opening"



**WARNING:** Cancer and Reproductive Harm  
[www.P65Warnings.ca.gov](http://www.P65Warnings.ca.gov)



## MAINTENANCE (BROOM CORE INSTALLATION)

1. Slide the idler-bearing lock collar over the idler shaft.
2. Install the idler shaft into the idler bearing using a mallet to seat it to its maximum depth.
3. Use the skid steer/loader to raise the attachment off the ground. Raise the feet to the top position.
4. Using the skid steer/loader, lower the attachment until the idler-bearing mounting plate can be bolted into place.
5. slide the motor drive into the broom core and use the skid steer/loader to adjust the attachment height until the motor mount can be bolted into place.
6. tighten the lock collar onto the idler bearing in the counterclockwise rotation using a hammer and punch.
7. Use an hex wrench to tighten the set screw on the lock collar.
8. Rotate the bumper back into position, install the two (2) bolts removed in the core removal process, and tighten the bolts' two (2) loosened bolts.



**Ensure all bolts have been adequately tightened before using the attachment. Failure to tighten all bolts could result in damage to the equipment or serious injury.**



**WARNING:** Cancer  
and Reproductive Harm  
[www.P65Warnings.ca.gov](http://www.P65Warnings.ca.gov)

# MAINTENANCE

## (MOTOR REPLACEMENT)

### Motor Replacement

In the case of motor failure, perform the following steps to replace the hydraulic motor.

1. Perform the “Maintenance Shutdown Procedure” stated on page 9.
2. Begin the motor replacement process by removing the broom core. See “Removing the Broom Core” for more details.
3. Disconnect the hydraulic hoses from the motor, collecting any hydraulic oil in an oil pan or other containment method.

TIP: Mark the forwardmost hose connected to the motor with a paint pin or other marking method for easier reinstallation.

NOTE: See your local regulations for proper waste oil disposal.

4. Remove the four (4) bolts attaching the motor to the motor mounting plate and remove the motor.
5. Use an hex key to remove the set screw from the square drive on the motor’s shaft.
6. Carefully slide the square drive off the motor shaft. When the square drive is removed, the motor shaft key will fall out of the retention slot. **DO NOT** lose the motor shaft key. Failure to reinstall the key could result in damage to the attachment.
7. Reinstall the motor shaft key, square drive, and set screw to the new motor. **ALWAYS** add a red thread locker to the square drive set screw.
8. Slide the motor into the mounting plate and reinstall the four (4) bolts to attach the motor to the mount.
9. Reconnect the hydraulic hoses and ensure that the hoses are installed in the correct motor ports and are adequately tightened.



**Failure to install the hoses in the correct motor ports affects the function of the attachment and causes the broom to rotate backward (towards the operator).**

10. Perform the broom core installation Process to reassemble the attachment. See “Broom Core Installation” for more details.



**WARNING:** Cancer  
and Reproductive Harm  
[www.P65Warnings.ca.gov](http://www.P65Warnings.ca.gov)

# MAINTENANCE

## (IDLER BEARING REPLACEMENT)

### Idler Bearing Replacement

In the case of idler bearing failure, perform the following steps to replace the idler bearing.

1. Perform the “Maintenance Shutdown Procedure” found on page 9.
2. Begin the motor replacement process by removing the broom core. See “Removing the Broom Core” for more details.
3. Remove the four (4) bolts that attach the idler bearing to the bearing mounting plate.
4. Install the new bearing to the mounting plate with the grease zerk facing away from the operator’s position.
5. Perform the broom core installation Process to reassemble the attachment. See “Broom Core Installation” for more details.



**WARNING:** Cancer  
and Reproductive Harm  
[www.P65Warnings.ca.gov](http://www.P65Warnings.ca.gov)

## MAINTENANCE (WATER SYSTEM)

### **Water System Maintenance**

The 40-gallon water system is an optional add-on and requires daily maintenance.

Check water system filters, nozzle screens, and cycle system daily.

Ensure the system is drained during storage or freezing weather.



**Failure to drain the water system can result in damage to the system.**

To drain the water system, unscrew the strainer cap, allowing water to drain out of the tank.



**WARNING:** Cancer  
and Reproductive Harm  
[www.P65Warnings.ca.gov](http://www.P65Warnings.ca.gov)

# MAINTENANCE (TROUBLESHOOTING)

PROBLEM	PROBABLE CAUSE	SOLUTION
Core motor shaft seal leak	<ol style="list-style-type: none"> <li>1. String line wrapped around shaft</li> <li>2. Excessive down pressure (Too much side load)</li> </ol>	<ol style="list-style-type: none"> <li>1. Remove string line and reseal motor</li> <li>2. Reseal motor. Instruct operator to use down pressure only when necessary.</li> </ol>
Core motor shaft broken	<ol style="list-style-type: none"> <li>1. Excessive down pressure (Too much side load)</li> </ol>	<ol style="list-style-type: none"> <li>1. Replace motor. Instruct operator to use down pressure only when necessary.</li> </ol>
Brush is Stalled	<ol style="list-style-type: none"> <li>1. Flow from Skid Steer is Backwards</li> <li>2. Valve pressure relief set to low</li> </ol>	<ol style="list-style-type: none"> <li>1. Reverse flow</li> <li>2. Call customer service for pressure setting</li> </ol>
Hydraulic motor won't start	<ol style="list-style-type: none"> <li>1. Bad electrical connection</li> <li>2. Debris in the hydraulic valve</li> <li>3. Defective motor</li> </ol>	<ol style="list-style-type: none"> <li>1. Ensure motor solenoids are receiving 5V</li> <li>2. Flush the hydraulic system or replace valve</li> <li>3. Replace motor</li> </ol>
Cylinder won't actuate	<ol style="list-style-type: none"> <li>1. Bad electrical Connection</li> <li>2. Debris in the hydraulic valve</li> <li>3. Blow cylinder seal</li> </ol>	<ol style="list-style-type: none"> <li>1. Ensure cylinder solenoids are receiving 5V</li> <li>2. Flush the hydraulic system or replace valve</li> <li>3. Replace cylinder</li> </ol>



**WARNING:** Cancer and Reproductive Harm  
www.P65Warnings.ca.gov



# SERVICE PARTS



**WARNING:** Cancer  
and Reproductive Harm  
[www.P65Warnings.ca.gov](http://www.P65Warnings.ca.gov)

# PARTS (FULL ASSEMBLY BREAK DOWN)

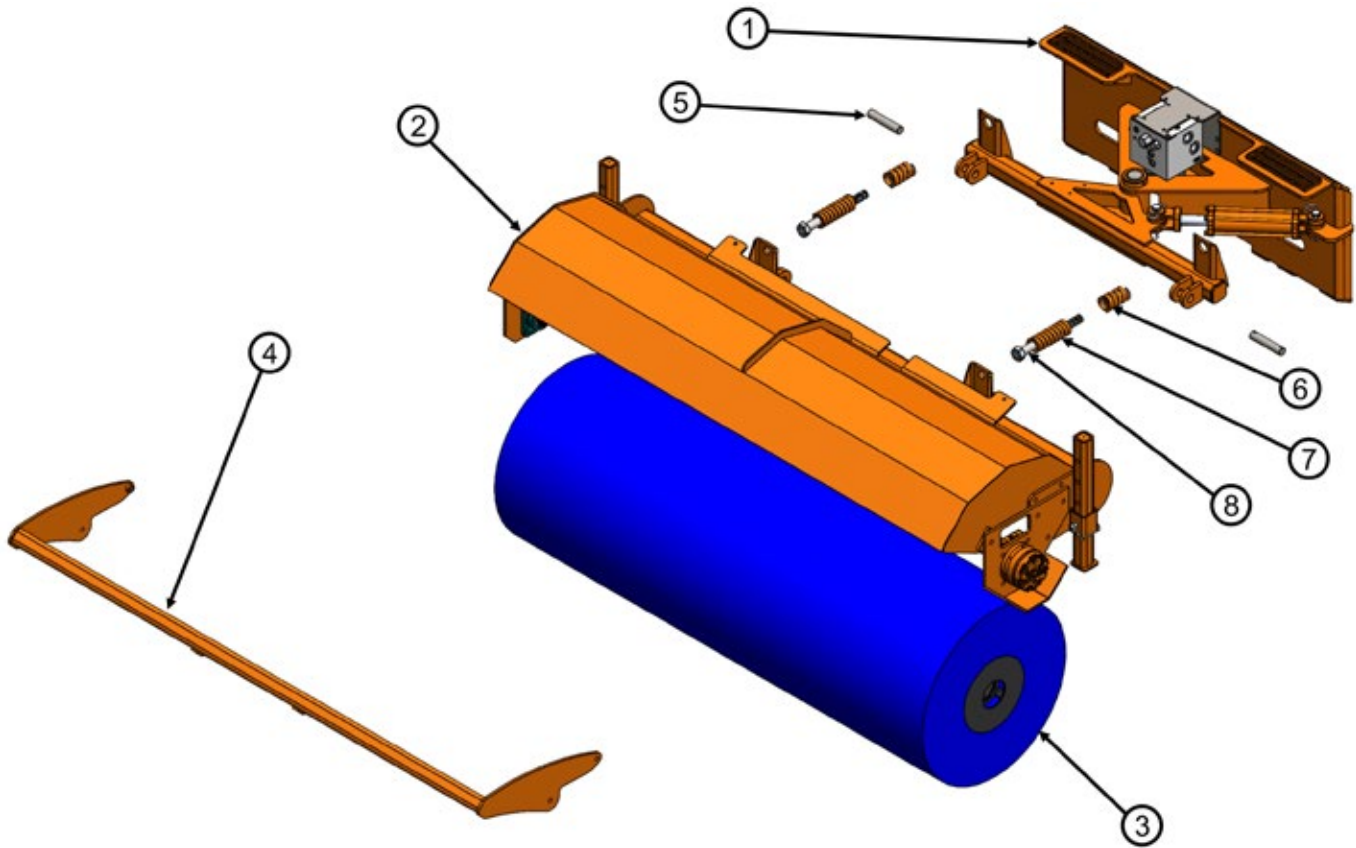

ITEM #	PARTS #	DESCRIPTION	QTY.
1	N/S	See "Pivot Assembly"	1
2	N/S	See "Cover Assembly"	1
3	N/S	See "Core Assembly"	1
4	800331	48" Angle Broom Bumper	1
5	1407	Core Hinge Pin	2
6	200342	48" & 60" Outside Spring	2
7	200339	48" Inside Spring	2
8	200334	Spring Guide Bolt	2
N/S	200571	Spring Guide Bolt Washer	4
N/S	447672	Spring Guide Bolt Nylock	2
N/S* = Not Shown			



**WARNING:** Cancer  
and Reproductive Harm  
[www.P65Warnings.ca.gov](http://www.P65Warnings.ca.gov)

# PARTS (COVER ASSEMBLY)

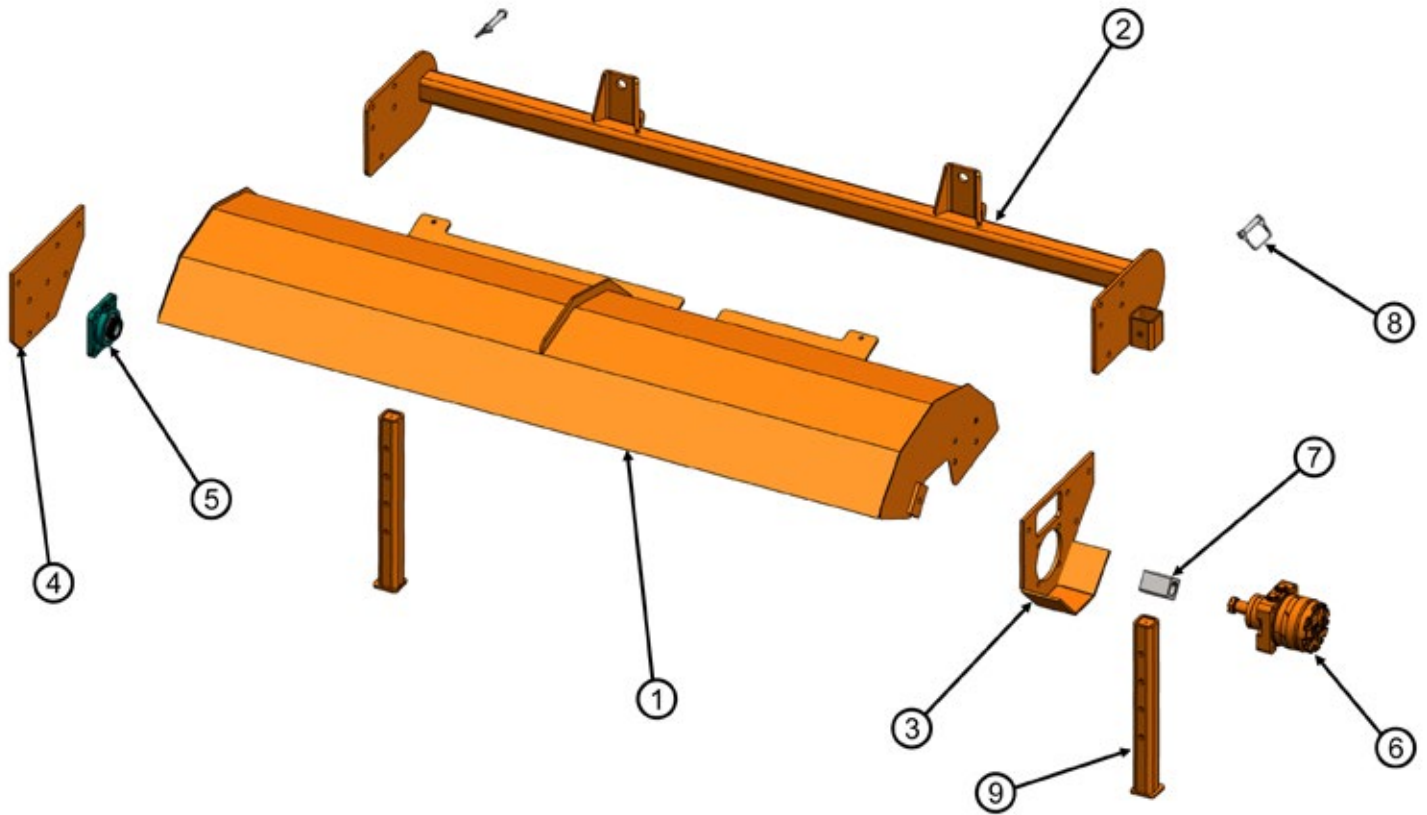

ITEM #	PARTS #	DESCRIPTION	QTY.
1	800346	48" Angle Broom Cover	1
2	800348	48" Angle Broom C Frame	1
3	390040	LH Core Motor Mount	1
4	202526	Idler Mounting Plate	1
5	320221	Idler Bearing	1
6	390535	Hydraulic Motor	1
7	389674	Block Broom Drive	1
8	200335	Wire Lock Clevis Pin	2
9	800323	Feet Assy	2



**WARNING:** Cancer  
and Reproductive Harm  
[www.P65Warnings.ca.gov](http://www.P65Warnings.ca.gov)



# PARTS (PIVOT ARM ASSEMBLY)

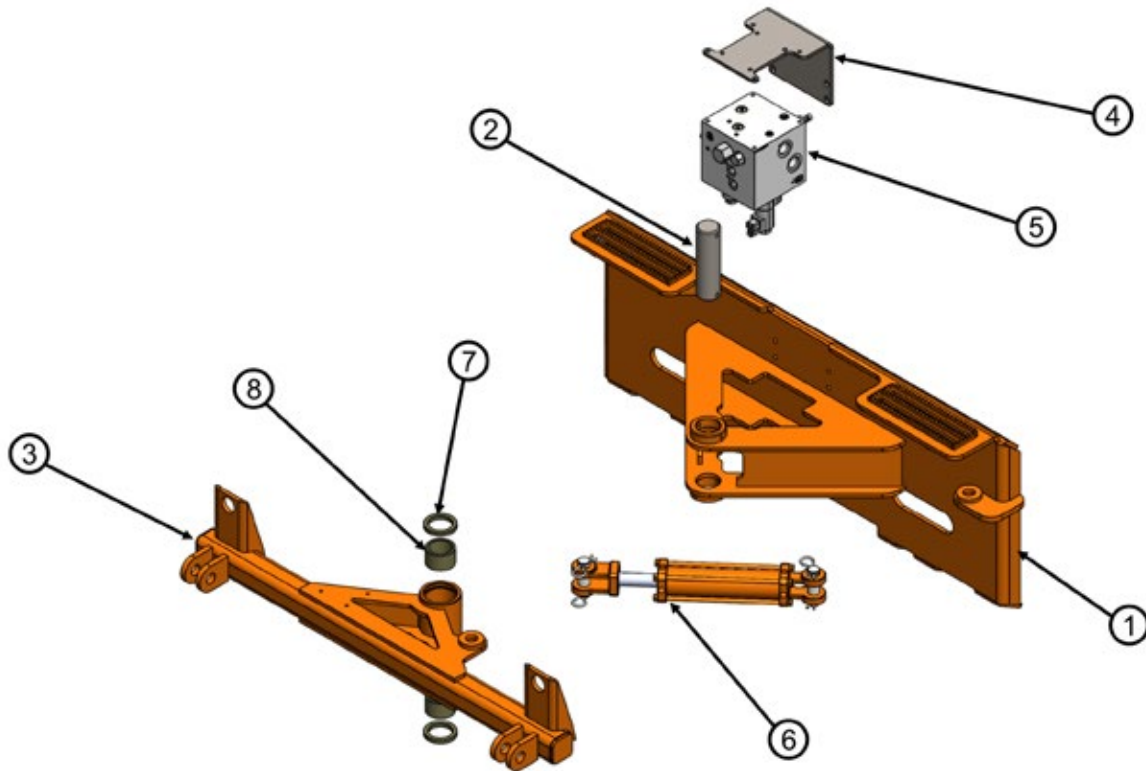

ITEM #	PARTS #	DESCRIPTION	QTY.
1	800310	Mechanism w/o Core Assy	1
2	200332	Pivot Pin	1
3	800316	Mech Float Hinge Portion	1
4	200574	Manifold Mount	1
5	200331	hyd. Angle Valve	1
6	200333	2" x 6" Cylinder	1
7	513237	Dust Seal	2
8	501601	Garmax Bushing	2



**WARNING:** Cancer and Reproductive Harm  
www.P65Warnings.ca.gov

# PARTS (CORE ASSEMBLY)

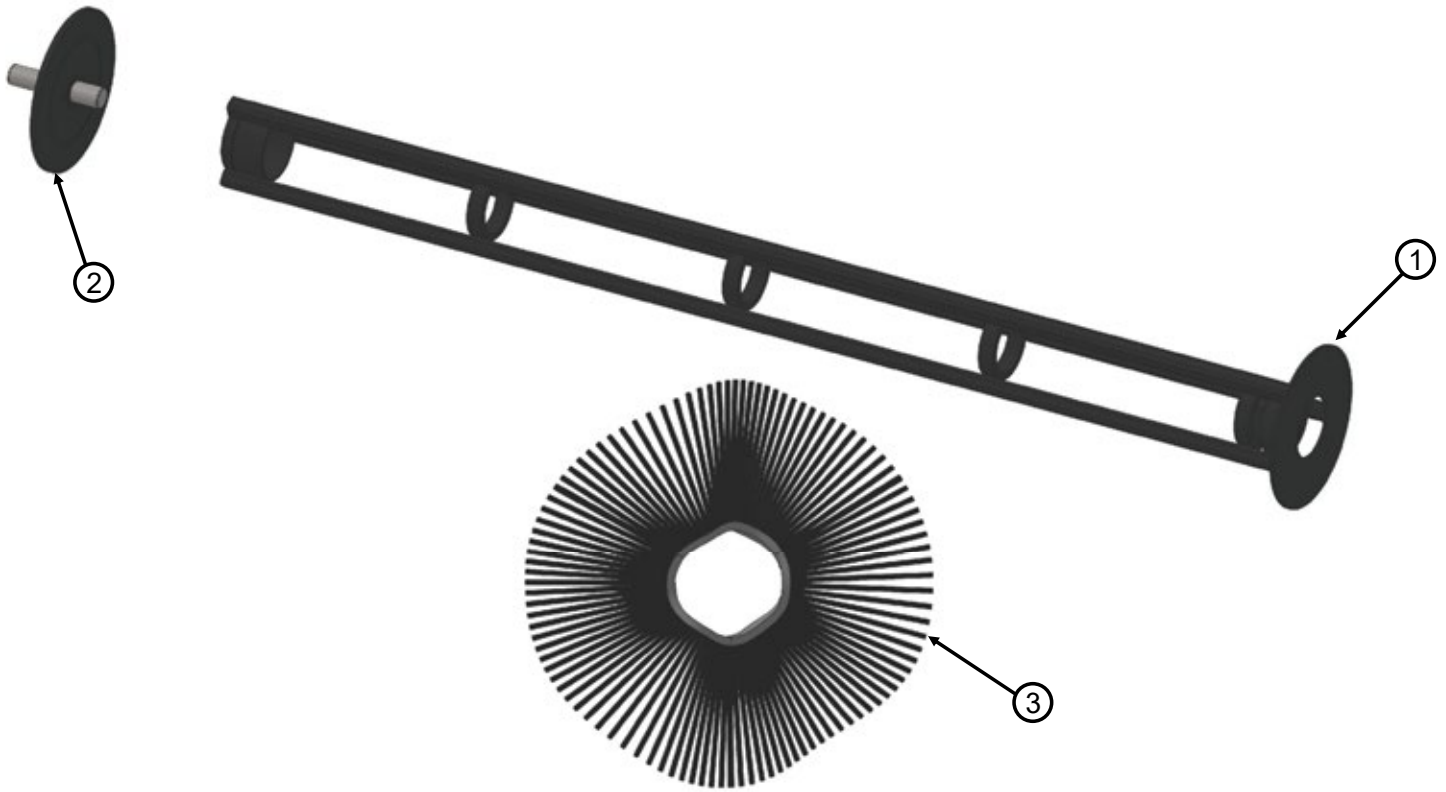

ITEM #	PARTS #	DESCRIPTION	QTY.
1	200426	48" Broom Core	1
2	391157	Idler Bearing Assembly	1
3	200454	24" x 48" Wafer Kit	1



**WARNING:** Cancer  
and Reproductive Harm  
[www.P65Warnings.ca.gov](http://www.P65Warnings.ca.gov)

# PARTS (Electrical)

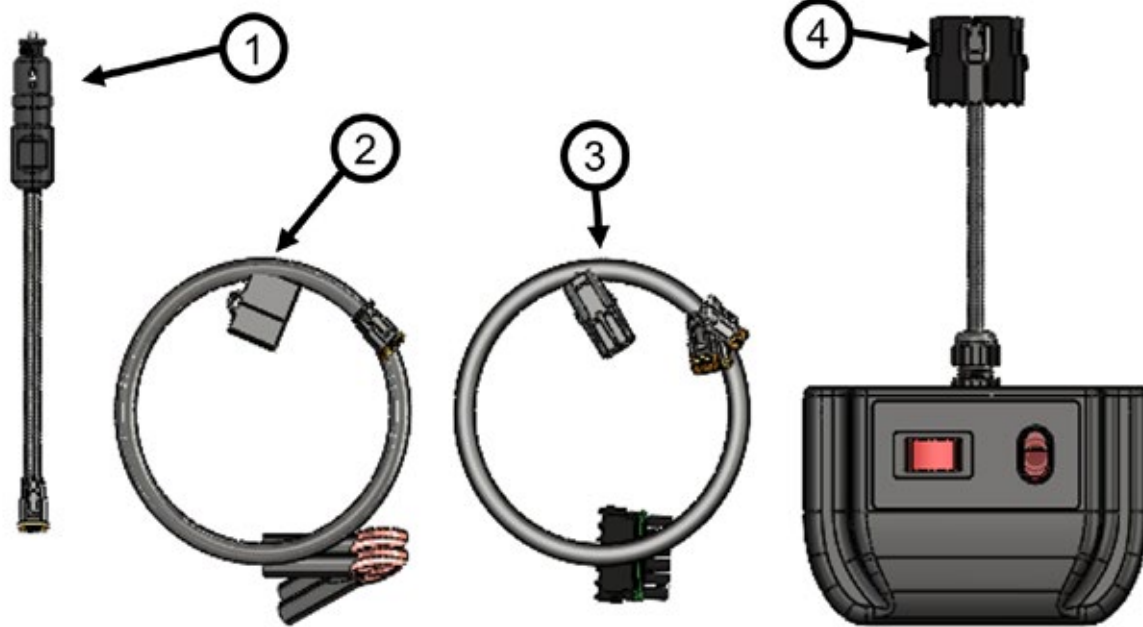

ITEM #	PARTS #	DESCRIPTION	QTY.
1	200432	Power Wire (Cig. Outlet)	1
2	200430	Power Wire (Battery)	1
3	200431	Hydraulic Angle Broom Main Wire	1
4	200442	Hydraulic Angle Broom Control Box (no spray)	1



**WARNING:** Cancer and Reproductive Harm  
www.P65Warnings.ca.gov

# SCHEMATICS

## (Hydraulic Diagram)

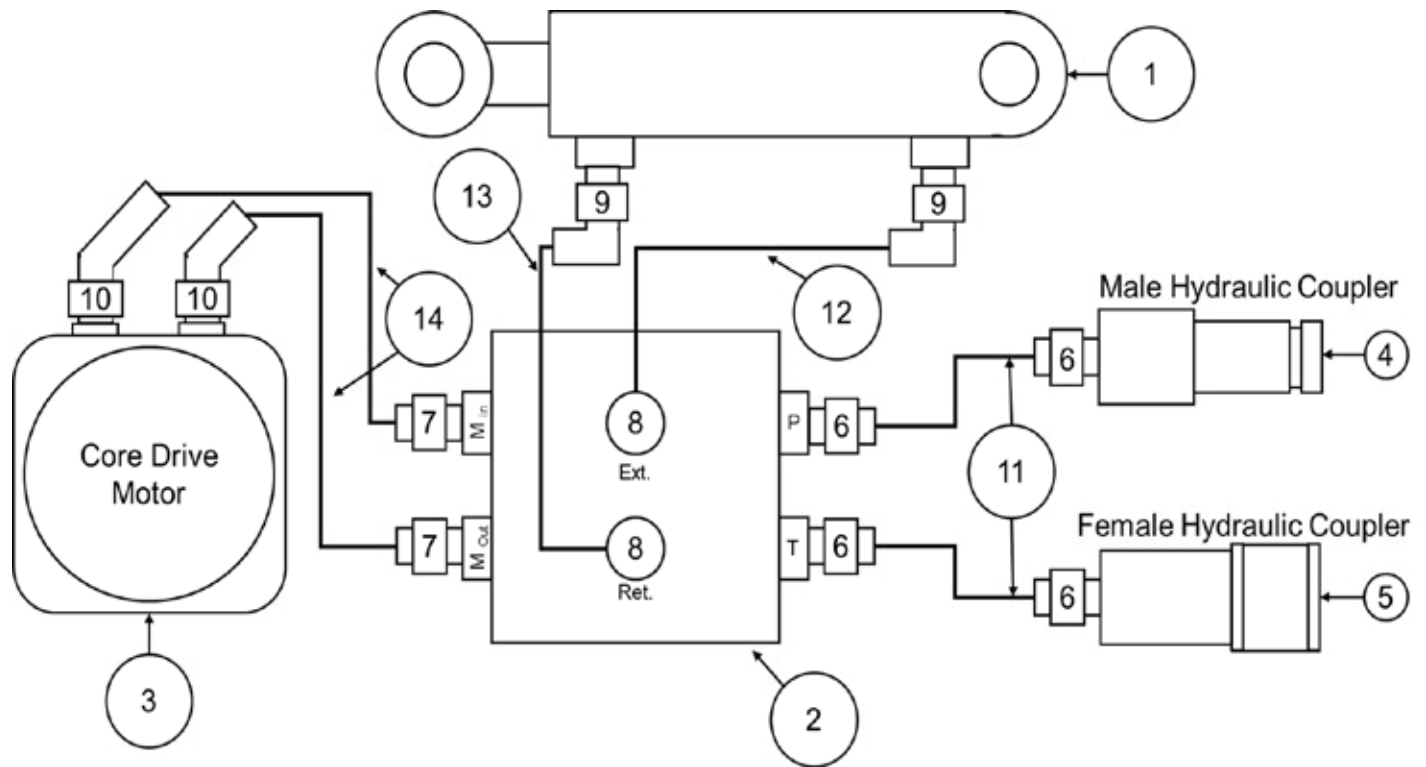

ITEM #	PARTS #	DESCRIPTION	QTY.
1	200333	2x6 Cylinder	1
2	200331	Hyd. Angle Valve	1
3	390535	Core Drive Motor	1
4	391107	Male Connect Under Pressure Coupler	1
5	391107F	Female Connect Under Pressure Coupler	1
6	389488	Adapter, 12 mfs - 12 morb STR	4
7	389824	Adapter, 10 mfs - 8 morb STR	5
8	513356	Adapter, 6 mfs - 6 morb STR	5
9	513353	Adapter, 6 mfs - 8 morb 90deg	5
10	389826	Adapter, 10 mfs - 10 morb 45deg	5
11	391190	Angle Broom Inlet and Outlet Hose	5
12	391191	Angle Broom Cylinder Extension Hose	1
13	391192	Angle Broom Cylinder Retraction Hose	1
14	391194	84" Angle Broom Motor In and Out Hose	2

**WARNING:** Cancer and Reproductive Harm  
[www.P65Warnings.ca.gov](http://www.P65Warnings.ca.gov)

# VALVE BREAKDOWN

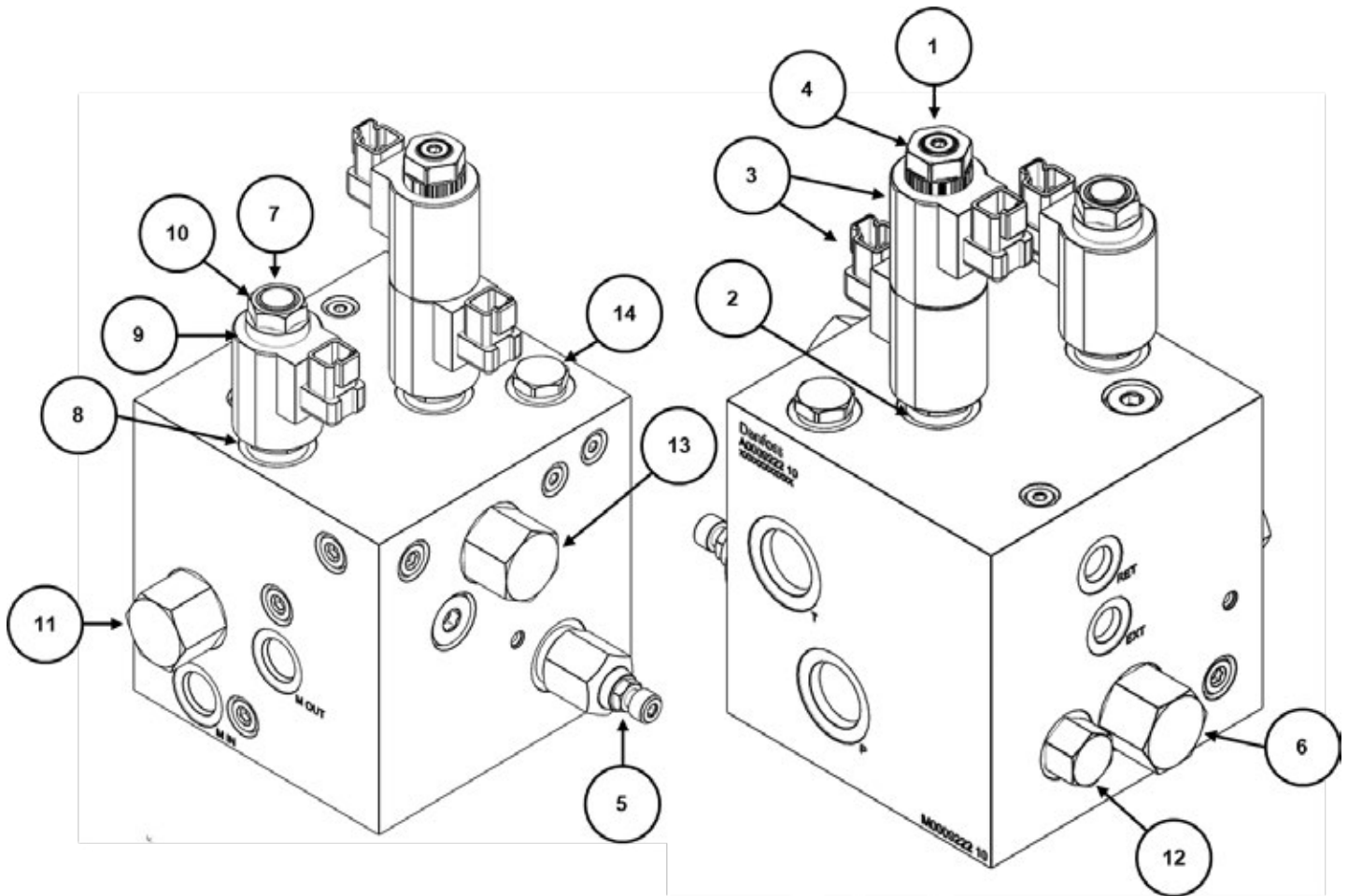

ITEM #	PARTS #	DESCRIPTION	QTY.
1	200550	Angle Directional Valve	1
2	200551	Actuator	1
3	200552	Coil	2
4	200553	Nut	1
5	200554	Relief Valve	1
6	200555	Compensator for Angle	1
7	200556	Angle Priority Valve	1
8	200557	Actuator	1
9	200558	Coil	1
10	200559	Nut	1
11	200560	Compensator for Motor	1
12	200561	Flow Control for Angle	1
13	200562	Flow Control for Motor	1
14	200563	Anticav Valve	1



**WARNING:** Cancer and Reproductive Harm  
www.P65Warnings.ca.gov

# DECALS

①



**⚠ WARNING**  
PINCH POINT HAZARD!  
Keep hands and feet clear!  
Failure to comply could result in death or serious injury.



③



**WARNING:** This product can expose you to chemicals including toluene, carbon black, cumene and ethylbenzene, which is known to the State of California to cause cancer and birth defects or other reproductive harm. For more information, go to: [www.P65Warnings.ca.gov](http://www.P65Warnings.ca.gov)

④



*Broce Broom*

⑤



**⚠ WARNING**  
  
**FLYING OBJECT HAZARD!  
STAY BACK!**  
Stay away from discharge area during operation.  
Keep others away.  
Do not point discharge toward people, animals or property.  
Failure to comply could result in death or serious injury.

⑥



**⚠ NO RIDERS**

⑦



**BBA 48H**

⑧



**BBA 48H**  
[WWW.BROCEBROOM.COM](http://WWW.BROCEBROOM.COM)

 **WARNING:** Cancer and Reproductive Harm  
[www.P65Warnings.ca.gov](http://www.P65Warnings.ca.gov)

# DECALS

ITEM #	PARTS #	DESCRIPTION	QTY.
N/S	200480	BBA48H Decal Kit	1
1	200501	Safety Decal - Pinch Point Hazard	2
2	390185	American Flag	1
3	312095	Prop 65	1
4	200365	Swirl Broce Broom Logo Decal	2
5	200506	Safety Decal - Flying Objects	2
6	443581	No Riders	2
7	200366	BBA48H Front Logo Decal	1
8	200367	BBA48H Side Logo Decal	2



**WARNING:** Cancer  
and Reproductive Harm  
[www.P65Warnings.ca.gov](http://www.P65Warnings.ca.gov)

# SERVICE PARTS TO STOCK

DESCRIPTION
24" wafers
Bumper
Motor
Idler bearing



**WARNING:** Cancer  
and Reproductive Harm  
[www.P65Warnings.ca.gov](http://www.P65Warnings.ca.gov)







**CALIFORNIA  
Proposition 65 Warning**

Diesel engine exhaust and some of its constituents are known to the State of California to cause cancer, birth defects, and other reproductive harm.  
For more information, visit: [www.P65Warnings.ca.gov](http://www.P65Warnings.ca.gov)

**WARNING:** Battery posts, terminal and related accessories contain lead and lead compounds, chemicals known to the State of California to cause cancer, birth defects, and other reproductive harm. Wash hands after handling.  
For more information, visit: [www.P65Warnings.ca.gov](http://www.P65Warnings.ca.gov)

Broce Manufacturing Co. Inc. - 1460 South 2nd Avenue - Dodge City, KS 67801  
(877) 227-8811 - FAX (620) 227-3012 - [parts@brocebroom.com](mailto:parts@brocebroom.com)  
M-F 7:00 AM-6:00 PM CST

**1-866-283-2759**

[www.brocebroom.com](http://www.brocebroom.com)