

Operation & Maintenance

Broce Broom

BBA84M

Skid Steer Broom Attachment



Broce Manufacturing Co. Inc. - 1460 South 2nd Avenue - Dodge City, KS 67801
(877) 227-8811 - FAX (620) 227-3012 - parts@brocebroom.com
M-F 7:00 AM-6:00 PM CST

1-866-283-2759

March 2024

www.brocebroom.com

**Broce Manufacturing Company, Inc.
WARRANTY REGISTRATION**

Purchased From (Dealership)

Company: _____
Address: _____
City: _____ State: ____ ZIP: _____
Delivery Date to Dealer: ____ / ____ / ____ Unit Hours: _____
Model Number: _____ Serial Number: _____

Purchaser

Company: _____
Address: _____
City: _____ State: ____ ZIP: _____
Delivery Date to Dealer: ____ / ____ / ____ Unit Hours: _____

| Purchaser - Type of Business | | | |
|-------------------------------------|--------------|--------------------|--|
| Construction/Highway | Rental | Asphalt Contractor | |
| Equipment Dealer | Municipality | Other | |

1. *The Purchaser has been instructed and/or has read the manual and understands proper preventive maintenance, operation and safety precautions.*
2. *The Warranty and Limitations of Liability are found in the Warranty pages enclosed in the Parts and Operators Manuals.*
3. *Broce Manufacturing Co. Inc. reserves the right to make design changes or modifications to Broce products at any time without incurring any obligation to make similar changes or modifications to previously sold units.*
4. *If this Document is not signed and returned to Broce Manufacturing Co. Inc., the warranty begins at the date of delivery to the Dealership.*

I hereby acknowledge acceptance of above and conditions in the Warranty Policy

Purchaser/Owner: _____

Dealer Representative: _____

Broce Manufacturing Co. Inc.
1460 South 2nd Avenue
Dodge City, KS 67801
(877) 227-8811

BROCE MANUFACTURING COMPANY
BROCE BROOM LIMITED TWELVE-MONTH WARRANTY

For a period of twelve (12) months or 1,000 hours whichever comes first, from the date of delivery of product to the original user, Broce Manufacturing of Dodge City, Kansas warrants each product to be free from manufacturing defects, subject to the limitations contained in this policy. This limited warranty covers parts and labor.

No alterations may be made to attachment without the expressed written consent of Broce Manufacturing company, as this could cause serious injury or death and will also void the warranty.

This warranty does not apply to defect caused, in whole or in part, by unreasonable use while in the possession of the user, including, but not limited to, failure to properly set up product, failure to provide reasonable and necessary maintenance, normal wear, routine tune ups or adjustments, improper handling, accidents, operation at speed or load conditions contrary to published specifications, improper or insufficient lubrication, or improper storage. This warranty is not a guarantee that the performance of each product will meet the expectations of the purchaser.

Broce Manufacturing shall not be liable for consequential damage of any kind, including, but not limited to: consequential labor costs or transportation charges in connection with the replacement or repair of defective parts, lost time or expense which may have accrued because of said defects. In no event shall Broce Manufacturing's total liability hereunder exceed the product purchase price.

Many components used by Broce Manufacturing are subject to the warranties of their respective manufacturers. These warranties will be considered void if the product is modified or repaired in any way not expressly authorized, or if closed components are disassembled prior to return. Closed components include, but are not limited to gearboxes, hydraulic pumps, motors, cylinders and actuators.

Our obligation under the warranty is expressly limited, at our option, to the replacement or repair at Broce Manufacturing of Dodge City, KS or at a service facility designated by us. We are not responsible for unauthorized repairs or replacements. Any implied or statutory warranties, including any warranty of merchantability or fitness for a particular purpose, are expressly limited to duration of this written warranty. We make no other express warranty. This warranty cannot be extended, broadened, or changed except in writing by an authorized officer of Broce Manufacturing.

Broce Manufacturing Co. Inc.
1460 South 2nd Avenue
Dodge City, KS 67801
(877) 227-8811

TABLE OF CONTENTS

| | |
|---------------------------------------|------------|
| <u>Safety Precautions</u> | <u>8-9</u> |
| <u>Attachment Specs</u> | <u>10</u> |
| <u>Serial Number Location</u> | <u>11</u> |
| <u>Attachment Operation.....</u> | <u>12</u> |
| <u>Connect Electrical System.....</u> | <u>13</u> |

Maintenance

| | |
|--|-----------|
| <u>Lubrication</u> | <u>14</u> |
| <u>Wafer Replacement</u> | <u>15</u> |
| <u>Broom Core Install</u> | <u>16</u> |
| <u>Motor Replacement.....</u> | <u>17</u> |
| <u>Idler Bearing Replacement</u> | <u>18</u> |
| <u>Water System.....</u> | <u>19</u> |
| <u>Troubleshooting</u> | <u>20</u> |

Parts

| | |
|-------------------------------------|--------------|
| <u>Full Assembly</u> | <u>22</u> |
| <u>Cover Assembly</u> | <u>23</u> |
| <u>Pivot Assembly.....</u> | <u>24</u> |
| <u>Broom Core Assembly</u> | <u>25</u> |
| <u>Water System.....</u> | <u>26-27</u> |
| <u>Hydraulic Diagram</u> | <u>28</u> |
| <u>Valve Breakdown</u> | <u>29</u> |
| <u>Decals</u> | <u>30-31</u> |
| | |
| <u>Service Parts to Stock</u> | <u>32</u> |
| <u>Notes</u> | <u>33</u> |



WARNING: Cancer
and Reproductive Harm
www.P65Warnings.ca.gov



DANGER



MISUSE, OPERATION OR MAINTENANCE BY AN UNAUTHORIZED PERSON COULD LEAD TO SERIOUS INJURY OR DEATH

Operation of this equipment shall be limited to a competent and experienced person. In addition, anyone who will operate or work around this equipment must use good common sense. In order to be qualified, he or she must also know and meet all other requirements, such as:

1. Some regulation specify that no one under the age of 16 may operate power machinery. It is your responsibility to know what these regulations are in your area or situation.
2. Current OSHA regulations state in part: "At the time of initial assignment and at least annually thereafter, the employer shall instruct **EVERY** employee in the safe operation of servicing of all equipment with which the employee is or will be involved."
3. Unqualified person must **STAY OUT** of the work area.
4. A person who has not read and understood all operating and safety instructions is not qualified to operate the machinery.
5. While machine is in operation, there should be no bystanders within 15 to 20 feet of the machine.
6. Absolutely **NO RIDERS** on the attachment.

FAILURE TO READ THIS MANUAL AND IT'S SAFETY INSTRUCTIONS IS A MISUSE OF THE EQUIPMENT AND WILL VOID FACTORY WARRANTY.



WARNING: Cancer
and Reproductive Harm
www.P65Warnings.ca.gov

SAFETY PRECAUTIONS

Entering and Exiting the Operator's Position



Only Enter or Exit the skid steer/loader where proper handholds and steps are available. Inspect the handholds and step for any damage prior to use and perform repairs when necessary. Keep all handholds and steps clean to avoid serious injury.

Maintain 3 contact points with the skid steer/loader and attachment when entering and exiting the operator's position. Face the skid steer/loader when entering and exiting the operator's position. NEVER enter, exit, climb, or jump on a moving or operating attachment.



Maintenance Shutdown Procedure

ALWAYS perform the "Maintenance Shutdown Procedure" **BEFORE** adjusting, lubricating, cleaning, or servicing the attachment. See below for the "Maintenance Shutdown Procedure".

1. Lower the boom arm and rotate the attachment until the bucket contacts the ground and sits flat.

 **WARNING** 
NEVER work beneath the attachment
while boom arms are raised.

2. Apply the parking brake, turn off the skid steer/loader engine, and remove the key from the ignition. **DO NOT** reinsert the key into the ignition until any required maintenance or adjustment is complete.
3. Relieve the pressure in the hydraulic lines by actuating the skid steer/loaders boom controls. NOTE: reference the skid steer/loader's manual for exact pressure relieving methods.
4. Disconnect the attachment's hydraulic lines from the skid steer/loader.

 **WARNING** 
Always wear eye protection, hearing
protection and dust mask for respiratory irritants.



WARNING: Cancer
and Reproductive Harm
www.P65Warnings.ca.gov

ATTACHMENT SPECIFICATIONS

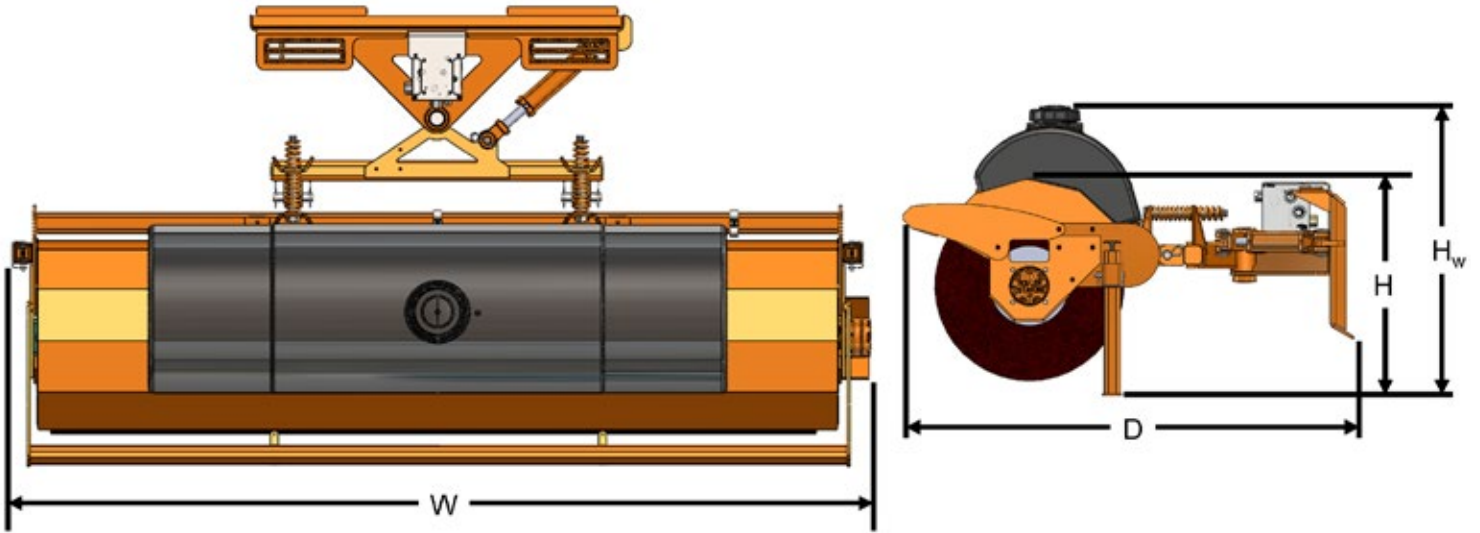

| BBA84M | |
|--|-----------|
| Brush Width | 84" |
| Overall Width (W) | 95" |
| Overall Depth (D) | 58.78" |
| Standard Package Overall Height (H) | 28" |
| Standard Package Weight (lb _s) | 715 lbs |
| Wafer Diameter | 24" |
| Input Flow Range | 12-30 GPM |
| Operating Pressure | 3000 PSI |
| Water System | Optional |
| Weight with Full Water System (lb _w) | 1115 lbs |
| Overall Height with Water System (H _w) | 36.68" |



WARNING: Cancer and Reproductive Harm
www.P65Warnings.ca.gov

SERIAL NUMBER LOCATION

The model/serial number plate is located on the left side of the support arm on the mounting plate. If the model/serial plate cannot be read, the serial number is stamped nearby. See the image below for more details.

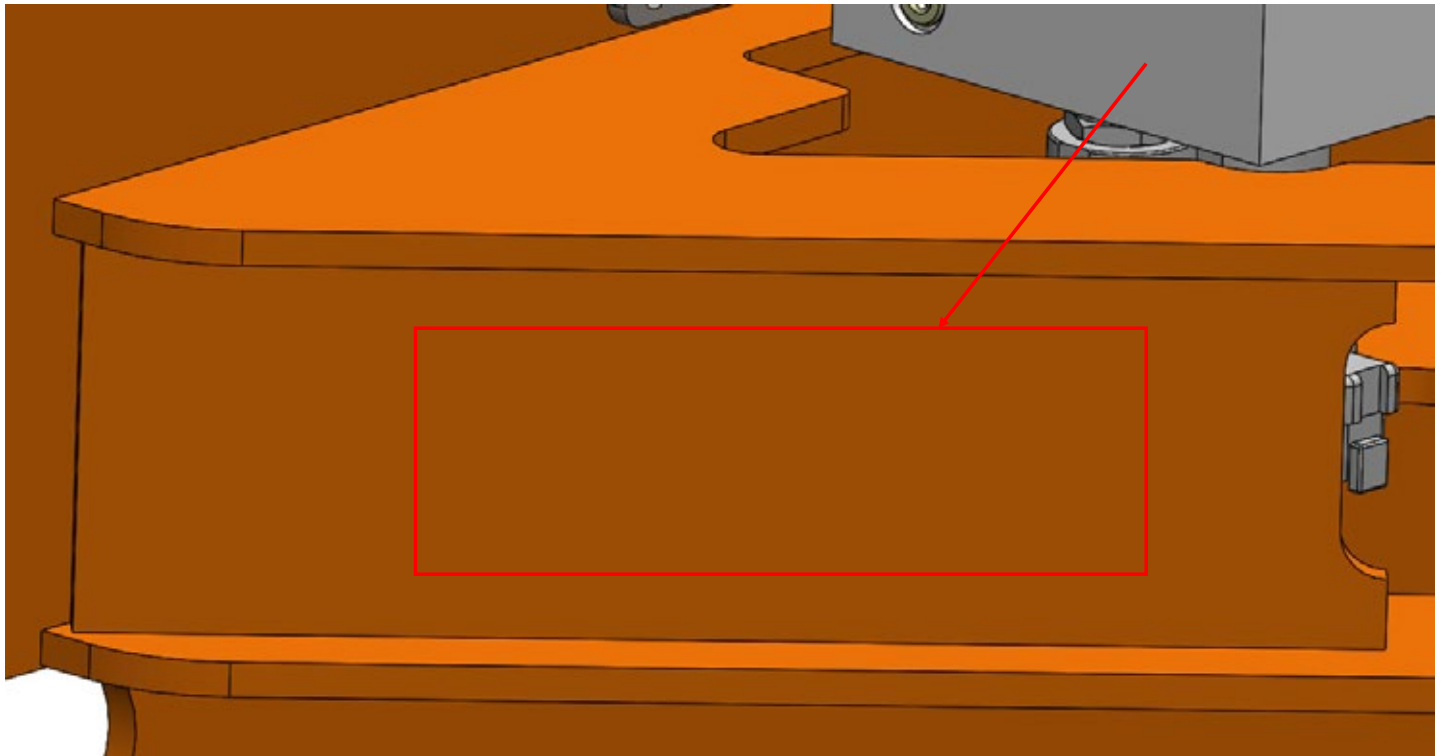

WARNING: Cancer
and Reproductive Harm
www.P65Warnings.ca.gov

ATTACHMENT OPERATION

Setup and Pre-use checks

Before operating the attachment, perform the following “Pre-use Checks.”

1. Ensure all safety decals are legible and free of excessive damage.
2. Check all hydraulic hoses and adapters for leaks and ensure they are tight.
3. Inspect all hydraulic hoses for damage or kinks. Hoses should be free to move during operation and dumping.
4. If the unit has an optional water system, check the wiring and water hose for potential catching or kinking.



Coupling the Attachment to a Skid Steer

1. Start the skid steer/loader engine, retract the attachment pins, and roll the coupler forward.
2. Center the skid steer/loader to the attachment and hook the coupler to the upper attachment strip. Roll the coupler backward and lift the attachment off the ground.
3. Actuate the attachment pins, ensuring the pins are completely engaged. Reference the skid steer/loader operations manual for more detail.

Connecting the Hydraulic Couplers

1. Perform the first three steps of the “Maintenance Shutdown Procedure” found on page 9 before connecting the hydraulic hoses to the skid steer/loader.
2. Inspect the hydraulic couplers for debris or damage prior to connecting the hoses. Clean or replace the couplers if necessary.
3. Press the couplers onto their corresponding couplers on the skid steer/loader. There should be an audible click when properly engaged.
4. Pull on the couplers to ensure they are properly connected.
5. Slowly roll the bucket back to check for interference between the hydraulic couplers and the bucket.
6. If the coupler interferes with the attachment, replace the coupler and straight adapter with the included stubby coupler and 90-degree adapter.



WARNING: Cancer
and Reproductive Harm
www.P65Warnings.ca.gov

CONNECTING THE ELECTRICAL SYSTEM (WATER SYSTEM ONLY)

The Broce Broom Manual Angle Brooms Water System option comes with a plug-and-play electrical system. Perform the following steps to install the electrical system.

1. Select your power method. The attachment includes two (2) different power methods: battery power and cigarette outlet power.
 - **Battery Power:**
Connect alligator clamps to battery (black to negative and red to positive) and fish power wire into cab of skid steer ensuring cable isn't at risk of snagging or kinking.
 - **Cigarette Outlet Power:**
2. Connect the controller to power.
3. Connect the attachment wire to the controller.



WARNING: Cancer
and Reproductive Harm
www.P65Warnings.ca.gov

MAINTENANCE (LUBRICATION)

The attachment has a grease zerk, as shown in the image below.

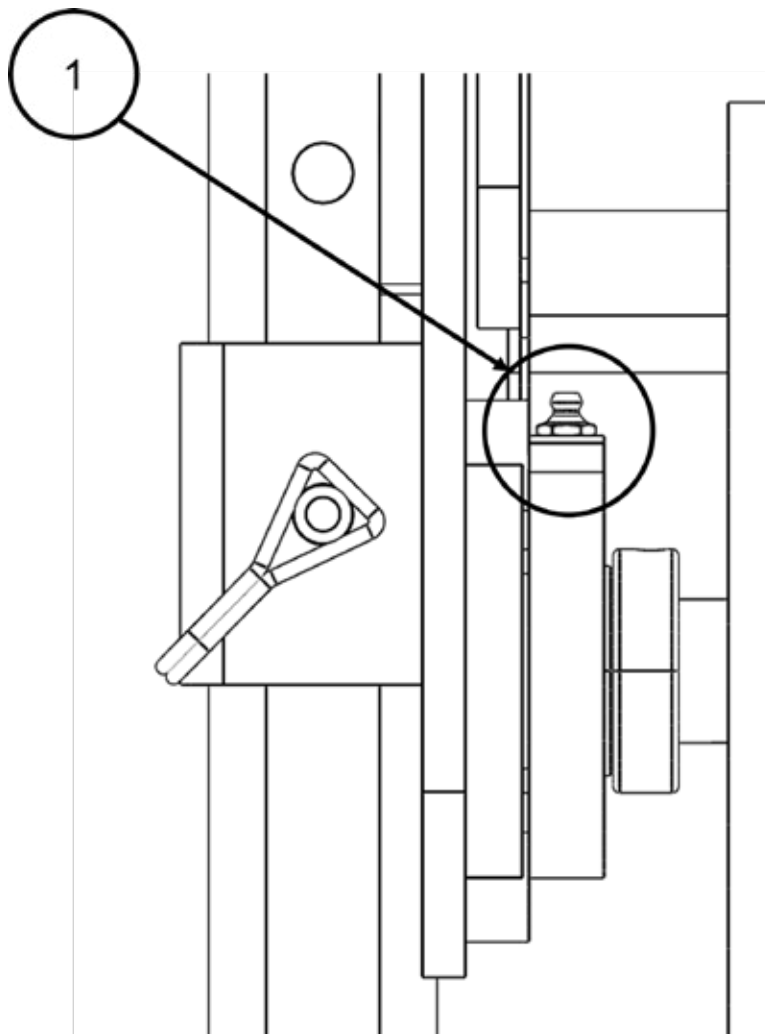

This is a sealed bearing and may require no lubrication throughout its service life. However, no more than two strokes of grease at 200-hour intervals are recommended if lubrication is deemed necessary. Seals are often destroyed by over-greasing sealed bearings. Perform the "Maintenance Shutdown Procedure" found on page 9 before greasing.

NOTE: The average grease gun outputs 0.025 - 0.035 ounces per stroke.



WARNING: Cancer
and Reproductive Harm
www.P65Warnings.ca.gov

MAINTENANCE

(BROOM WAFER REPLACEMENT)

Wafer Maintenance

The Broce Broom Attachment line uses a 10" x 24" convoluted wafer. See the table below for wafer quantities for 96 inch core.

| Core Length (in) | Number of Wafers Required |
|------------------|---------------------------|
| 84 | 46 |



IMPORTANT



Replacement wafer kits can be ordered from Broce Manufacturing at www.brocebroomparts.com or call 1-580-227-3711.

Removing the Broom Core

1. Lower the feet to the lowest pin position, then lower the boom arm and rotate the attachment until the feet and lower edge of the attachment plate contact the ground.
2. Perform the "Maintenance Shutdown Procedure" found on page 9.
3. Use an hex wrench to loosen the set screw on the idler-bearing lock ring.
4. Use a punch and hammer to turn the idler-bearing lock ring clockwise until the ring is loose.
5. Remove the two (2) forwardmost bolts from the bumper and loosen the two (2) rear bumper bolts to allow the bumper to hinge up out of the way.
6. Remove the remaining three (3) bolts from the motor mounting plate and put the motor and mount aside. **DO NOT REMOVE THE MOTOR FROM THE MOTOR MOUNT OR DISCONNECT THE HYDRAULIC HOSES FROM THE MOTOR.**
7. Pull the core from the motor side until the core is removed from the bearing. Set the core aside to change the brush wafers. See "Replacing the Brush Wafers" for proper wafer replacement instructions.
8. Remove the remaining three (3) bolts from the idler-bearing mounting plate and set aside for broom core reinstallation.



IMPORTANT



See page 25 for specific wafer kit ordering information.

Replacing the Brush Wafers

1. Rotate the broom core onto its motor side end.
2. Remove the 3 bolts holding on the idler assembly and remove the idler.
3. Remove each wafer by sliding them off the core.
4. Before installing new wafers, ensure the broom core is free of damage.
5. Install the wafers one at a time, clocking each 120° offset from the last wafer. A "diamond-shaped" opening should be visible when wafers are properly installed. See the image below for more details.
6. Reinstall the idler assembly.

"Diamond-Shaped Opening"



WARNING: Cancer and Reproductive Harm
www.P65Warnings.ca.gov

MAINTENANCE (BROOM CORE INSTALLATION)

1. Slide the idler-bearing lock collar over the idler shaft.
2. Install the idler shaft into the idler bearing using a mallet to seat it to its maximum depth.
3. Use the skid steer/loader to raise the attachment off the ground. Raise the feet to the top position.
4. Using the skid steer/loader, lower the attachment until the idler-bearing mounting plate can be bolted into place.
5. slide the motor drive into the broom core and use the skid steer/loader to adjust the attachment height until the motor mount can be bolted into place.
6. tighten the lock collar onto the idler bearing in the counterclockwise rotation using a hammer and punch.
7. Use an hex wrench to tighten the set screw on the lock collar.
8. Rotate the bumper back into position, install the two (2) bolts removed in the core removal process, and tighten the bolts' two (2) loosened bolts.



Ensure all bolts have been adequately tightened before using the attachment. Failure to tighten all bolts could result in damage to the equipment or serious injury.



WARNING: Cancer
and Reproductive Harm
www.P65Warnings.ca.gov

MAINTENANCE

(MOTOR REPLACEMENT)

Motor Replacement

In the case of motor failure, perform the following steps to replace the hydraulic motor.

1. Perform the “Maintenance Shutdown Procedure” stated on page 9.
2. Begin the motor replacement process by removing the broom core. See “Removing the Broom Core” for more details.
3. Disconnect the hydraulic hoses from the motor, collecting any hydraulic oil in an oil pan or other containment method.

TIP: Mark the forwardmost hose connected to the motor with a paint pin or other marking method for easier reinstallation.

NOTE: See your local regulations for proper waste oil disposal.

4. Remove the four (4) bolts attaching the motor to the motor mounting plate and remove the motor.
5. Use an hex key to remove the set screw from the square drive on the motor’s shaft.
6. Carefully slide the square drive off the motor shaft. When the square drive is removed, the motor shaft key will fall out of the retention slot. DO NOT lose the motor shaft key. Failure to reinstall the key could result in damage to the attachment.
7. Reinstall the motor shaft key, square drive, and set screw to the new motor. ALWAYS add a red thread locker to the square drive set screw.
8. Slide the motor into the mounting plate and reinstall the four (4) bolts to attach the motor to the mount.
9. Reconnect the hydraulic hoses and ensure that the hoses are installed in the correct motor ports and are adequately tightened.



Failure to install the hoses in the correct motor ports affects the function of the attachment and causes the broom to rotate backward (towards the operator).

10. Perform the broom core installation Process to reassemble the attachment. See “Broom Core Installation” for more details.



WARNING: Cancer
and Reproductive Harm
www.P65Warnings.ca.gov

MAINTENANCE

(IDLER BEARING REPLACEMENT)

Idler Bearing Replacement

In the case of idler bearing failure, perform the following steps to replace the idler bearing.

1. Perform the “Maintenance Shutdown Procedure” found on page 9.
2. Begin the motor replacement process by removing the broom core. See “Removing the Broom Core” for more details.
3. Remove the four (4) bolts that attach the idler bearing to the bearing mounting plate.
4. Install the new bearing to the mounting plate with the grease zerk facing away from the operator’s position.
5. Perform the broom core installation Process to reassemble the attachment. See “Broom Core Installation” for more details.



WARNING: Cancer
and Reproductive Harm
www.P65Warnings.ca.gov

MAINTENANCE (WATER SYSTEM)

Water System Maintenance

The 40-gallon water system is an optional add-on and requires daily maintenance.

Check water system filters, nozzle screens, and cycle system daily.

Ensure the system is drained during storage or freezing weather.



Failure to drain the water system can result in damage to the system.

To drain the water system, unscrew the strainer cap, allowing water to drain out of the tank.



WARNING: Cancer
and Reproductive Harm
www.P65Warnings.ca.gov

MAINTENANCE (TROUBLESHOOTING)

| PROBLEM | PROBABLE CAUSE | SOLUTION |
|----------------------------|--|--|
| Core motor shaft seal leak | <ol style="list-style-type: none"> 1. String line wrapped around shaft 2. Excessive down pressure (Too much side load) | <ol style="list-style-type: none"> 1. Remove string line and reseal motor 2. Reseal motor. Instruct operator to use down pressure only when necessary. |
| Core motor shaft broken | <ol style="list-style-type: none"> 1. Excessive down pressure (Too much side load) | <ol style="list-style-type: none"> 1. Replace motor. Instruct operator to use down pressure only when necessary. |
| Brush is Stalled | <ol style="list-style-type: none"> 1. Flow from Skid Steer is Backwards 2. Valve pressure relief set to low | <ol style="list-style-type: none"> 1. Reverse flow 2. Call customer service for pressure setting |



WARNING: Cancer and Reproductive Harm
www.P65Warnings.ca.gov

SERVICE PARTS



WARNING: Cancer
and Reproductive Harm
www.P65Warnings.ca.gov

PARTS (FULL ASSEMBLY BREAK DOWN)

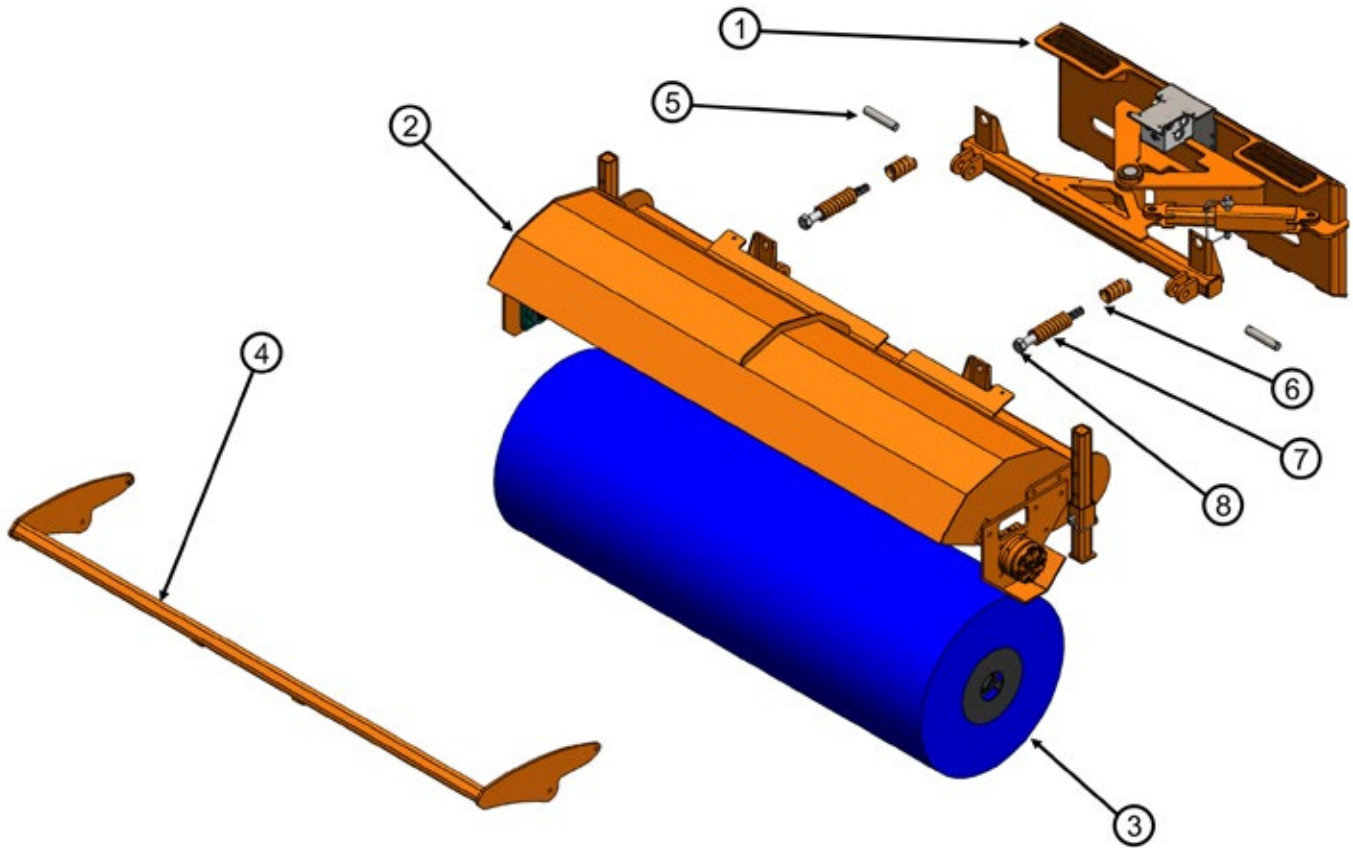

| ITEM # | PARTS # | DESCRIPTION | QTY. |
|------------------|---------|--------------------------|------|
| 1 | N/S | See "Pivot Assembly" | 1 |
| 2 | N/S | See "Cover Assembly" | 1 |
| 3 | N/S | See "Core Assembly" | 1 |
| 4 | 800358 | 84" Angle Broom Bumper | 1 |
| 5 | 1407 | Core Hinge Pin | 2 |
| 6 | 200341 | 72" & 84" Outside Spring | 2 |
| 7 | 200338 | Inside Spring | 2 |
| 8 | 200334 | Spring Guide Bolt | 2 |
| N/S | 200571 | Spring Guide Bolt Washer | 4 |
| N/S | 447672 | Spring Guide Bolt Nylock | 2 |
| N/S* = Not Shown | | | |

 **WARNING:** Cancer and Reproductive Harm
www.P65Warnings.ca.gov

PARTS (COVER ASSEMBLY)

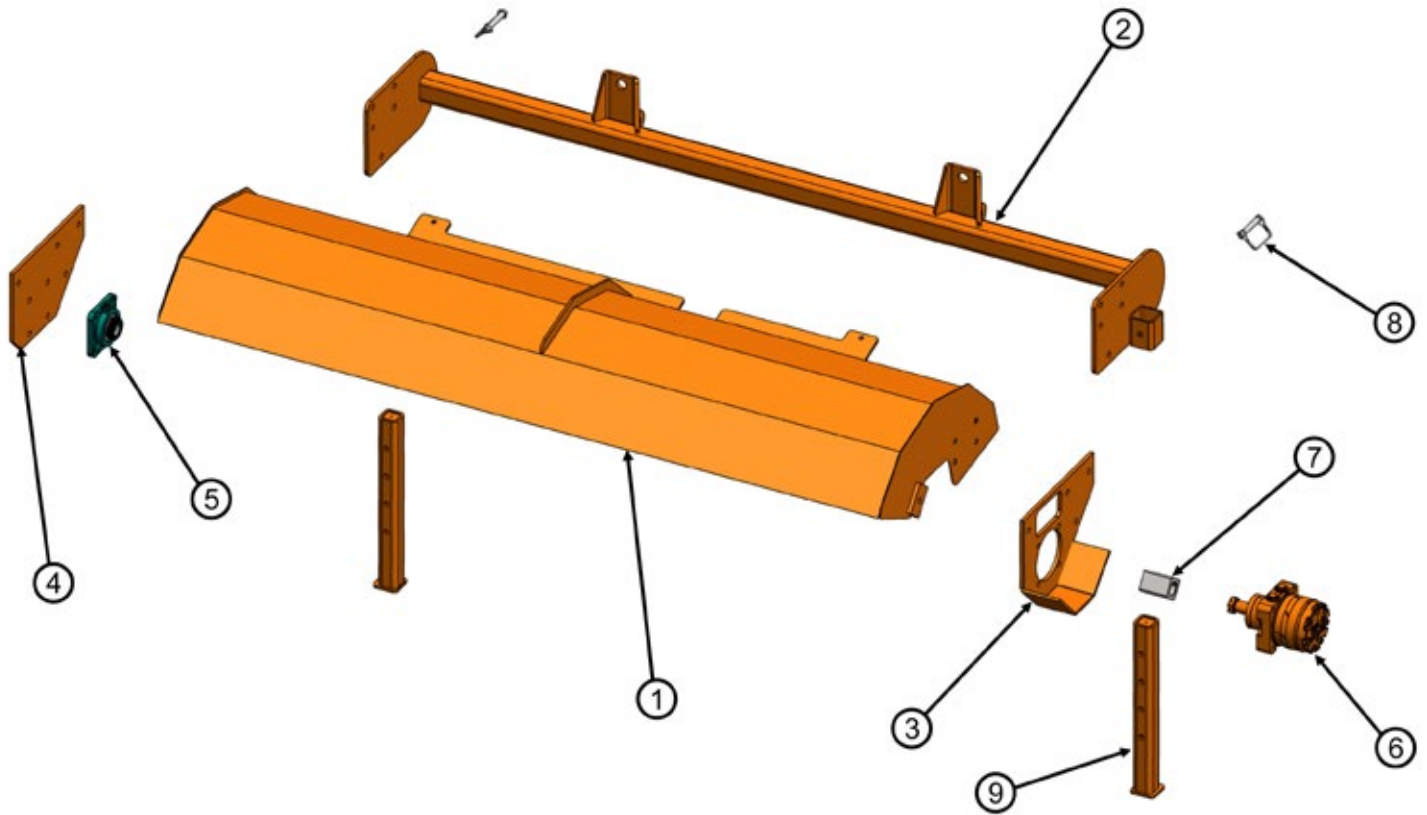

| ITEM # | PARTS # | DESCRIPTION | QTY. |
|--------|---------|-------------------------|------|
| 1 | 800357 | 84" Angle Broom Cover | 1 |
| 2 | 800356 | 84" Angle Broom C Frame | 1 |
| 3 | 390040 | LH Core Motor Mount | 1 |
| 4 | 202526 | Idler Mounting Plate | 1 |
| 5 | 320221 | Idler Bearing | 1 |
| 6 | 390535 | Hydraulic Motor | 1 |
| 7 | 389674 | Block Broom Drive | 1 |
| 8 | 200335 | Wire Lock Clevis Pin | 2 |
| 9 | 800323 | Feet Assy | 2 |



WARNING: Cancer and Reproductive Harm
www.P65Warnings.ca.gov

PARTS (PIVOT ARM ASSEMBLY)

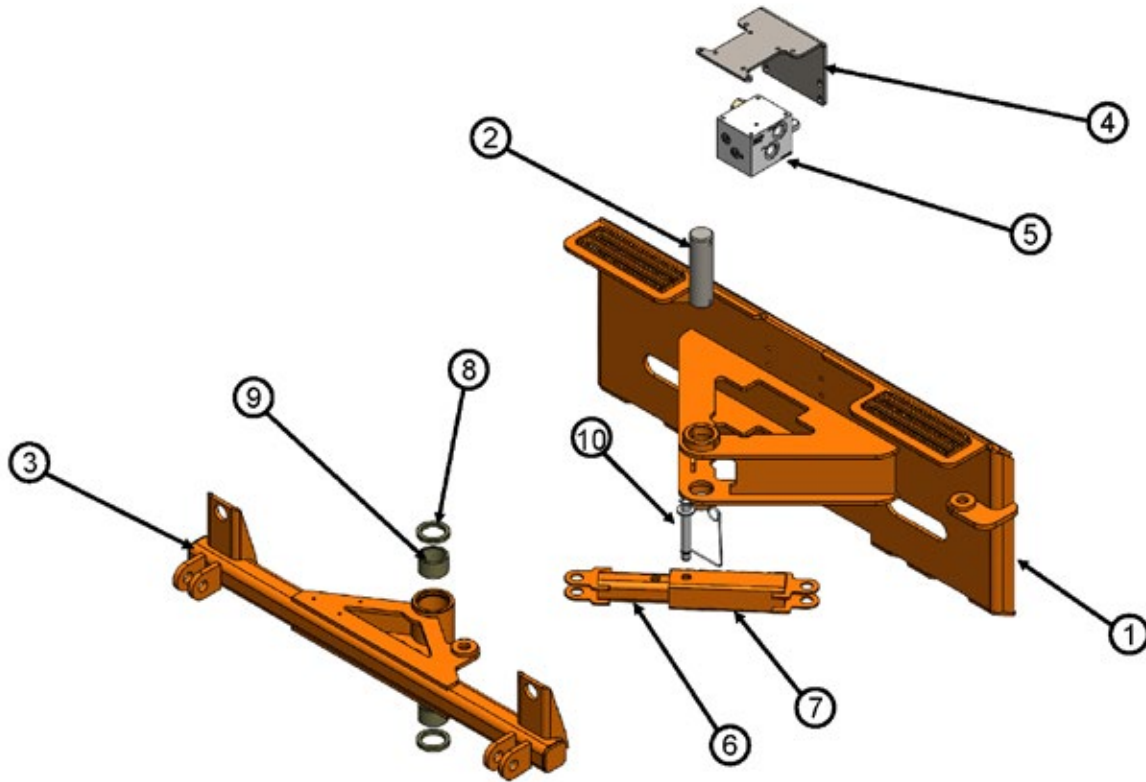

| ITEM # | PARTS # | DESCRIPTION | QTY. |
|------------------|---------|-----------------------------|------|
| 1 | 800310 | Mechanism w/o Core Assy | 1 |
| 2 | 200332 | Pivot Pin | 1 |
| 3 | 800316 | Mech Float Hinge Portion | 1 |
| 4 | 200574 | Manifold Mount | 1 |
| 5 | 200331 | hyd. Angle Valve | 1 |
| 6 | 800354 | Internal Manual Slider Assy | 1 |
| 7 | 800355 | External Manual Slider Assy | 1 |
| N/S | 15768 | Cylinder Pin | 1 |
| 8 | 513237 | Dust Seal | 2 |
| 9 | 501601 | Garmax Bushing | 2 |
| 10 | 15769 | 3/4 slider pin | 1 |
| N/S* = Not Shown | | | |

WARNING: Cancer and Reproductive Harm
www.P65Warnings.ca.gov

PARTS (CORE ASSEMBLY)

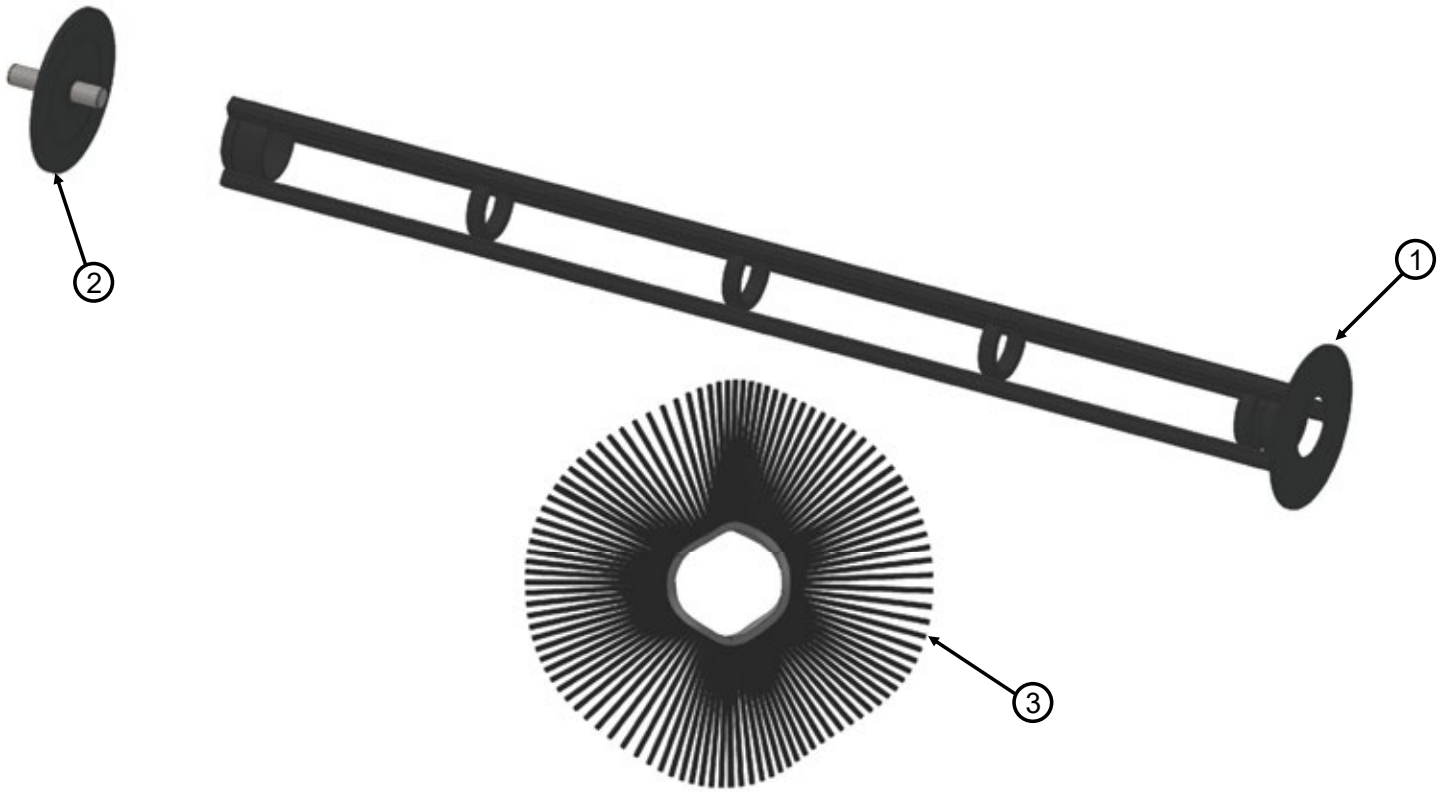

| ITEM # | PARTS # | DESCRIPTION | QTY. |
|--------|---------|------------------------|------|
| 1 | 200446 | 84" Broom Core | 1 |
| 2 | 391157 | Idler Bearing Assembly | 1 |
| 3 | 200457 | 24" x 84" Wafer Kit | 1 |



WARNING: Cancer and Reproductive Harm
www.P65Warnings.ca.gov

PARTS (Water System)

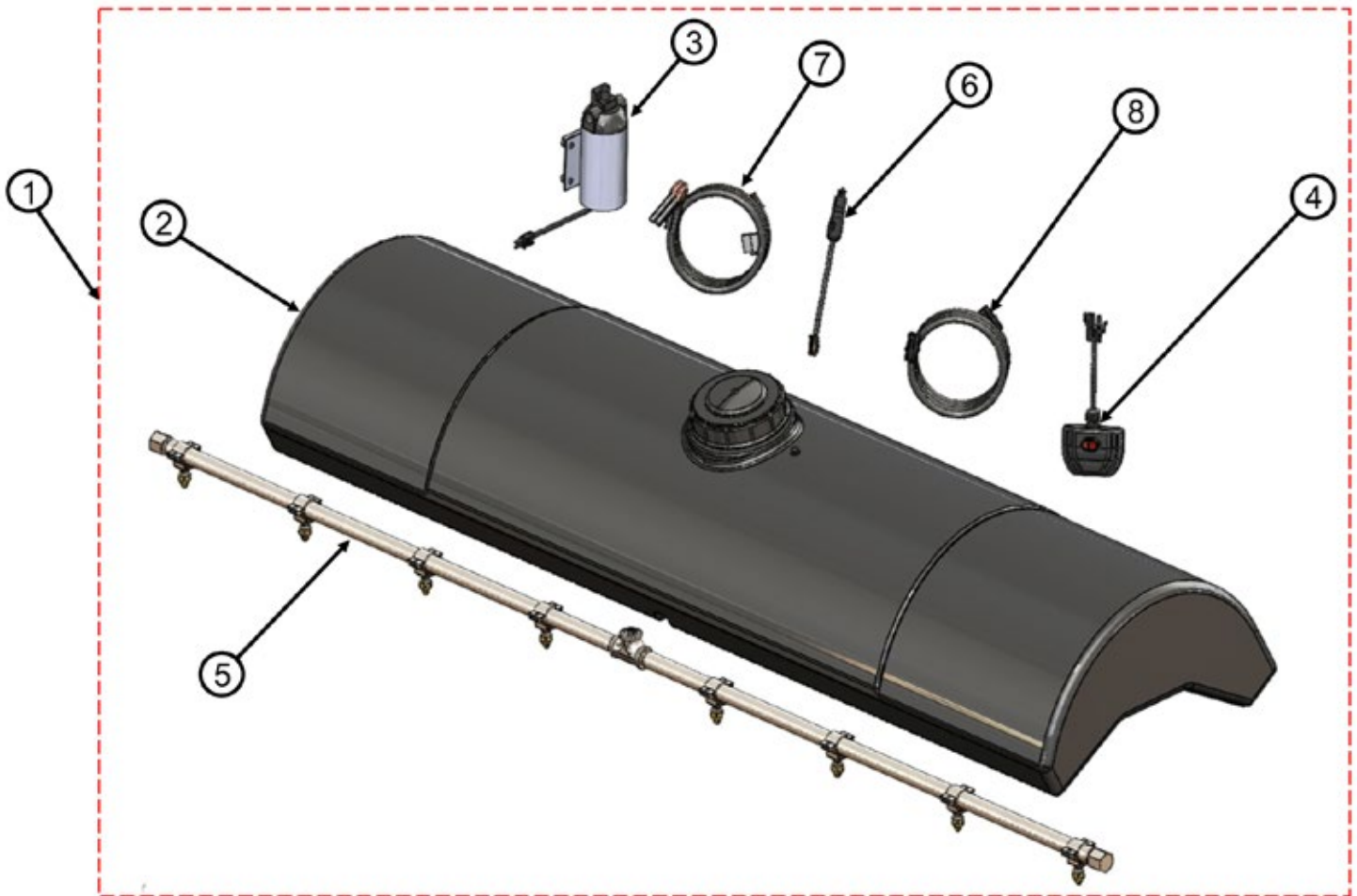

WARNING: Cancer
and Reproductive Harm
www.P65Warnings.ca.gov

PARTS

(Water System Cont.)

| ITEM # | PARTS # | DESCRIPTION | QTY. |
|------------------|---------|--|------|
| 1 | 200621 | 84" & 96" M Water Kit | |
| 2 | 800328 | Tank | 1 |
| 3 | 390047 | Water Pump | 1 |
| 4 | 391102 | hyd. Angle broom Control Box w/ Spray | 1 |
| 5 | 390442 | Spray Bar Assembly | 1 |
| 6 | 200432 | Power Wire (Cig. Outlet) | 1 |
| 7 | 200430 | Power Wire (Battery) | 1 |
| 8 | 200431 | Hydraulic Angle Broom Main Wire | 1 |
| N/S | 200406 | Tank Strap | 2 |
| N/S | 389802 | Inline Strainer | 1 |
| N/S | 389808 | 1/2 pvc Check Valve | 1 |
| N/S | 200401 | Angle Broom Water Hose, Tank to Ball Valve | 1 |
| N/S | 200402 | Angle Broom Water Hose, Pump to Check Valve | 1 |
| N/S | 200403 | Angle Broom Water Hose, Check Valve to Spray Bar | 1 |
| N/S | 389799 | 3/4 mnpt - 1/2 90 deg | 1 |
| N/S | 514411 | 1/2 Hose Clamp | 1 |
| N/S | 389798 | 3/4 mnpt - 1/2 barb STR | 1 |
| N/S | 389809 | 3/4 pvc Ball Valve | 1 |
| N/S | 389812 | 3/4 Close Nipple | 1 |
| N/S | 389813 | bushing 3/4 mnpt - 3/8 FMPT | 1 |
| N/S | 389811 | 3/8 close nipple | 1 |
| N/S | 389483 | Fitting 3/8 mnpt - 1/2 barb STR | 1 |
| N/S | 389810 | 1/2 mnpt - 1/2 barb STR | 1 |
| N/S | 35394 | 5/16 - 18 x 10" J-bolt | 1 |
| N/S | 426080 | 5/16 - 18 Nylock Nut | 1 |
| N/S | 442203 | 5/16 - 18 x 1" Self Tapper | 1 |
| N/S | 10363 | 5/16 - 18 x 1.75 Hex Head Bolt | 1 |
| N/S | 10561 | 5/16 Lockwasher | 1 |
| N/S | 36392 | 1/4 - 20 Nylock | 1 |
| N/S | 389873 | 1/4 - 20 x 1.5 U-bolt | 1 |
| N/S* = Not Shown | | | |



WARNING: Cancer and Reproductive Harm
www.P65Warnings.ca.gov

SCHEMATICS (Hydraulic Diagram)

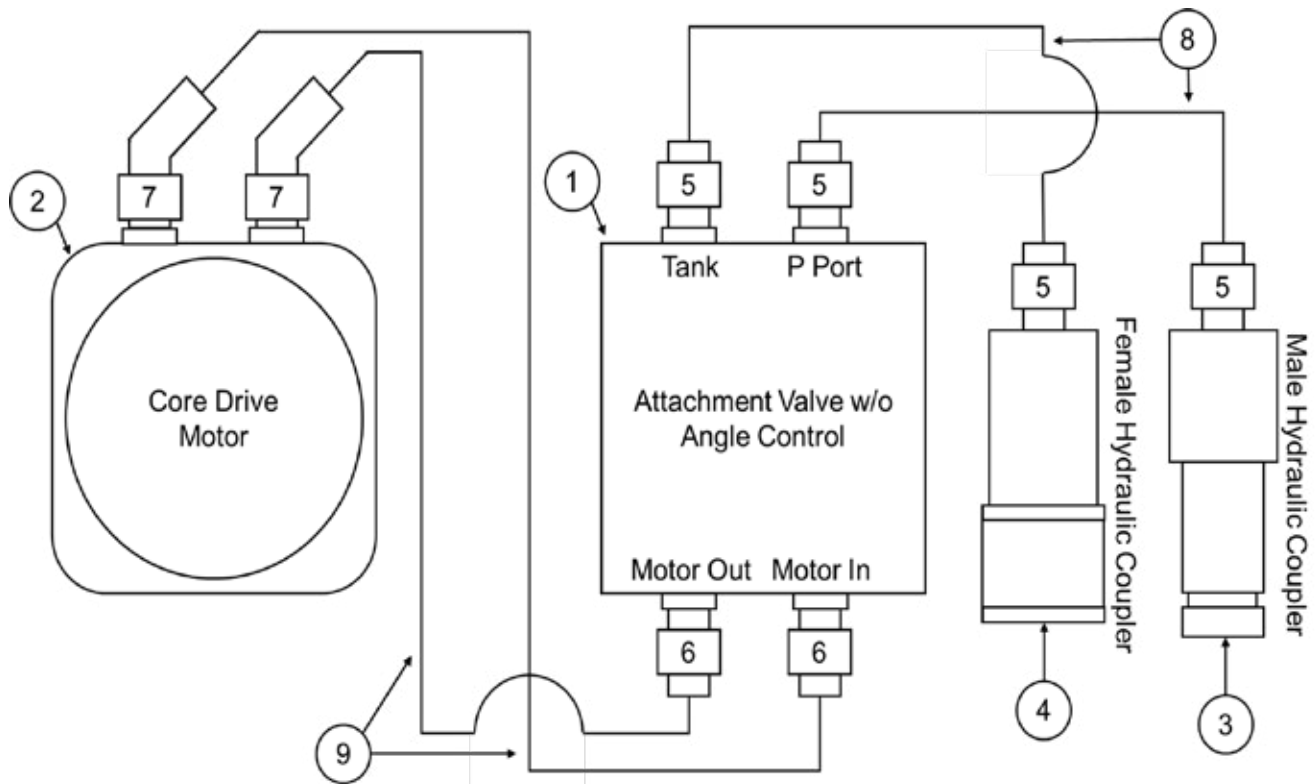

| ITEM # | PARTS # | DESCRIPTION | QTY. |
|--------|---------|--|------|
| 1 | 391101 | Attachment Valve w/o Angle Control | 1 |
| 2 | 390535 | Core Drive Motor | 1 |
| 3 | 391107 | Male Hydraulic Coupler | 1 |
| 4 | 391107F | Female Hydraulic Coupler | 1 |
| 5 | 389488 | Adapter, 12 mfs - 12 morb STR | 4 |
| 6 | 390018 | Adapter, 10 mfs - 12 morb STR | 2 |
| 7 | 389826 | Adapter, 12 mfs - 10 morb STR | 2 |
| 8 | 391190 | Angle Broom Inlet and Outlet Hose | 2 |
| 9 | 391187 | 84" Manual Angle Broom Motor In and Out Hose | 2 |

 **WARNING:** Cancer and Reproductive Harm
www.P65Warnings.ca.gov

VALVE BREAKDOWN

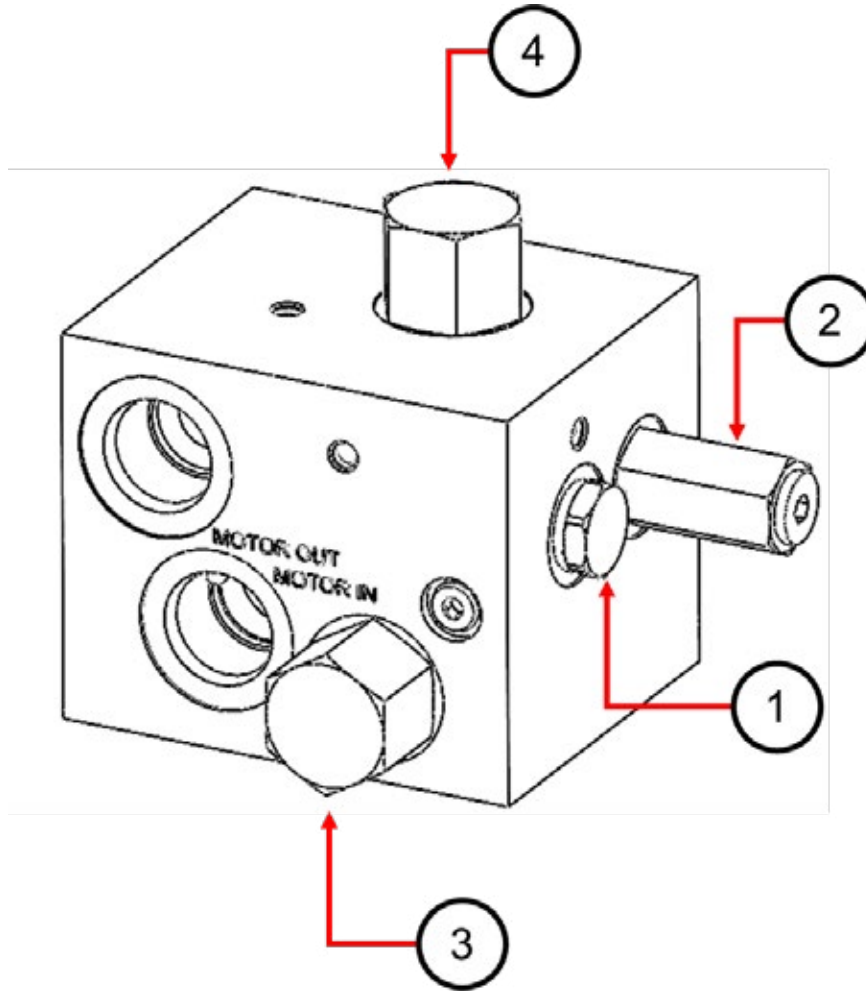

| ITEM # | PARTS # | DESCRIPTION | QTY. |
|--------|---------|---------------|------|
| 1 | 200563 | Anticav Valve | 1 |
| 2 | 200564 | Relief Valve | 1 |
| 3 | 200565 | Flow Control | 1 |
| 4 | 200266 | Compensator | 1 |



WARNING: Cancer and Reproductive Harm
www.P65Warnings.ca.gov

DECALS

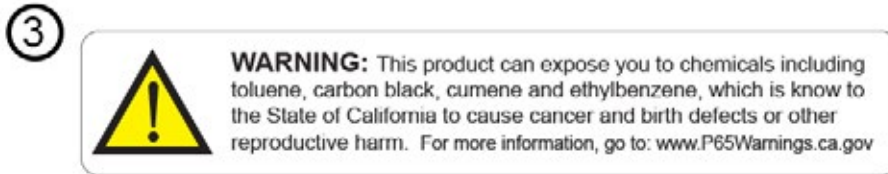

DECALS

| ITEM # | PARTS # | DESCRIPTION | QTY. |
|--------|---------|-----------------------------------|------|
| N/S | 200489 | BBA84M Decal Kit | 1 |
| 1 | 200501 | Safety Decal - Pinch Point Hazard | 2 |
| 2 | 390185 | American Flag | 1 |
| 3 | 312095 | Prop 65 | 1 |
| 4 | 200365 | Swirl Broce Broom Logo Decal | 2 |
| 5 | 200506 | Safety Decal - Flying Objects | 2 |
| 6 | 443581 | No Riders | 2 |
| 7 | 200393 | BBA84M Front Logo Decal | 2 |
| 8 | 200394 | BBA84M Side Logo Decal | 2 |



WARNING: Cancer
and Reproductive Harm
www.P65Warnings.ca.gov

SERVICE PARTS TO STOCK

| DESCRIPTION |
|---------------|
| 24" wafers |
| Bumper |
| Motor |
| Idler bearing |



WARNING: Cancer
and Reproductive Harm
www.P65Warnings.ca.gov



CALIFORNIA Proposition 65 Warning

Diesel engine exhaust and some of its constituents are known to the State of California to cause cancer, birth defects, and other reproductive harm.
For more information, visit: www.P65Warnings.ca.gov

WARNING: Battery posts, terminal and related accessories contain lead and lead compounds, chemicals known to the State of California to cause cancer, birth defects, and other reproductive harm. Wash hands after handling.
For more information, visit: www.P65Warnings.ca.gov

Broce Manufacturing Co. Inc. - 1460 South 2nd Avenue - Dodge City, KS 67801
(877) 227-8811 - FAX (620) 227-3012 - parts@brocebroom.com
M-F 7:00 AM-6:00 PM CST

1-866-283-2759

www.brocebroom.com