

Broce Broom

Parts Catalog

250-Series

Mid-Mount 3-Wheel Sweepers

Serial Numbers

305373 and higher

Broce Manufacturing Co. Inc.

1460 South 2nd Avenue

Dodge City, KS 67801

(877) 227-8811

(620) 227-3012 fax

parts@brocebroom.com

www.brocebroom.com

M-F 7:00 AM-6:00 PM CST

Broce Manufacturing Company, Inc. WARRANTY REGISTRATION

Purchased From (Dealership)			
Company:	_____		
Address:	_____		
City:	_____	State: ____	ZIP: _____
Delivery Date to Dealer:	___ / ___ / ___	Unit Hours:	_____
Model Number:	_____	Serial Number:	_____

Purchaser			
Company:	_____		
Address:	_____		
City:	_____	State: ____	ZIP: _____
Delivery Date to Owner:	___ / ___ / ___	Unit Hours:	_____

Purchaser - Type of Business				
Construction/Highway		Rental		Asphalt Contractor
Equipment Dealer		Municipality		Other

1. *The Purchaser has been instructed and/or has read the manual and understands proper preventive maintenance, operation and safety precautions.*
2. *The Warranty and Limitations of Liability are found in the Warranty pages enclosed in the Parts and Operators Manuals.*
3. *Broce Manufacturing Co. Inc. reserves the right to make design changes or modifications to Broce products at any time without incurring any obligation to make similar changes or modifications to previously sold units.*
4. *If this Document is not signed and returned to Broce Manufacturing Co. Inc., the warranty begins at the date of delivery to the Dealership.*

I hereby acknowledge acceptance of above and conditions in the Warranty Policy

Purchaser/Owner: _____

Dealer Representative: _____

Broce Manufacturing Co. Inc.
 1460 South 2nd Avenue
 Dodge City, KS 67801
 | (877) 227-8811 phone | (620) 227-3012 fax |

BROCE MANUFACTURING COMPANY

LIMITED TWELVE MONTH WARRANTY

For a period of twelve (12) months or 1,000 hours whichever comes first, from the date of delivery of product to the original user, Broce Manufacturing of Dodge City, Kansas warrants each product to be free from manufacturing defects, subject to the limitations contained in this policy. This limited warranty covers parts and labor.

This warranty does not apply to defect caused, in whole or in part, by unreasonable use while in the possession of the user, including, but not limited to, failure to properly set up product, failure to provide reasonable and necessary maintenance, normal wear, routine tune ups or adjustments, improper handling, accidents, operation at speed or load conditions contrary to published specifications, improper or insufficient lubrication, or improper storage. This warranty is not a guarantee that the performance of each product will meet the expectations of the purchaser.

Broce Manufacturing shall not be liable for consequential damage of any kind, including, but not limited to: consequential labor costs or transportation charges in connection with the replacement or repair of defective parts, lost time or expense which may have accrued because of said defects. In no event shall Broce Manufacturing be liable for any compensatory or consequential damage. In no event shall Broce Manufacturing's total liability hereunder exceed the product purchase price.

Many components used by Broce Manufacturing are subject to the warranties of their respective manufacturers. These warranties will be considered void if the product is modified or repaired in any way not expressly authorized, or if closed components are disassembled prior to return. Closed components include, but are not limited to gearboxes, hydraulic pumps, motors, cylinders and actuators.

Our obligation under the warranty is expressly limited, at our option, to the replacement or repair at Broce Manufacturing of Dodge City, KS or at a service facility designated by us. We are not responsible for unauthorized repairs or replacements. Any implied or statutory warranties, including any warranty of merchantability or fitness for a particular purpose, are expressly limited to duration of this written warranty. We make no other express warranty. This warranty cannot be extended, broadened, or changed except in writing by an authorized officer of Broce Manufacturing.

Broce Manufacturing Co. Inc.

1460 South 2nd Avenue

Dodge City, KS 67801

(877) 227-8811

TABLE OF CONTENTS

DESCRIPTION	PAGE #
<u>WARRANTY</u>	4
<u>SPECIFICATIONS</u>	6
<u>START UP AND PROPELLING</u>	8
<u>TOWING PROCEDURES</u>	9
<u>OPERATION OF THE SWEEPING CORE</u>	10
<u>SWEEPING TIPS</u>	12
<u>EXTENDING BRUSH LIFE</u>	13
<u>MACHINE OPERATION AND SAFETY</u>	14
<u>MACHINE CONTROL LOCATIONS</u>	17
<u>MACHINE SERVICE AND SAFETY GUIDELINES</u>	21
<u>LUBRICATION AND MAINTENANCE</u>	22
<u>BRAKE INSPECTION AND SERVICE</u>	23
<u>ENGINE</u>	24
<u>STORAGE</u>	24
<u>BROOM WAFERS</u>	24
<u>REPAIR PARTS</u>	25-57
<u>WIRING DIAGRAMS</u>	58+

MODEL BB-250

Specification Sheet

Engine Horsepower	24 H.P.
Machine Weight	3,000 LB
.....	3,600 LB w/Water System
Brush Diameters	6 3/8" ID X 24" OD
Broom Length	Full 8 FT
Broom Drive.....	Hydraulic Motor
Broom Angle	Full 40° (both ways)
Steering.....	60° (both ways)
Fuel Capacity	9 GAL
Hydraulic Oil Capacity.....	15 GAL
Speed	0 to 8 M.P.H.
Inside Sweeping Radius	5 FT
Water System	72 GAL

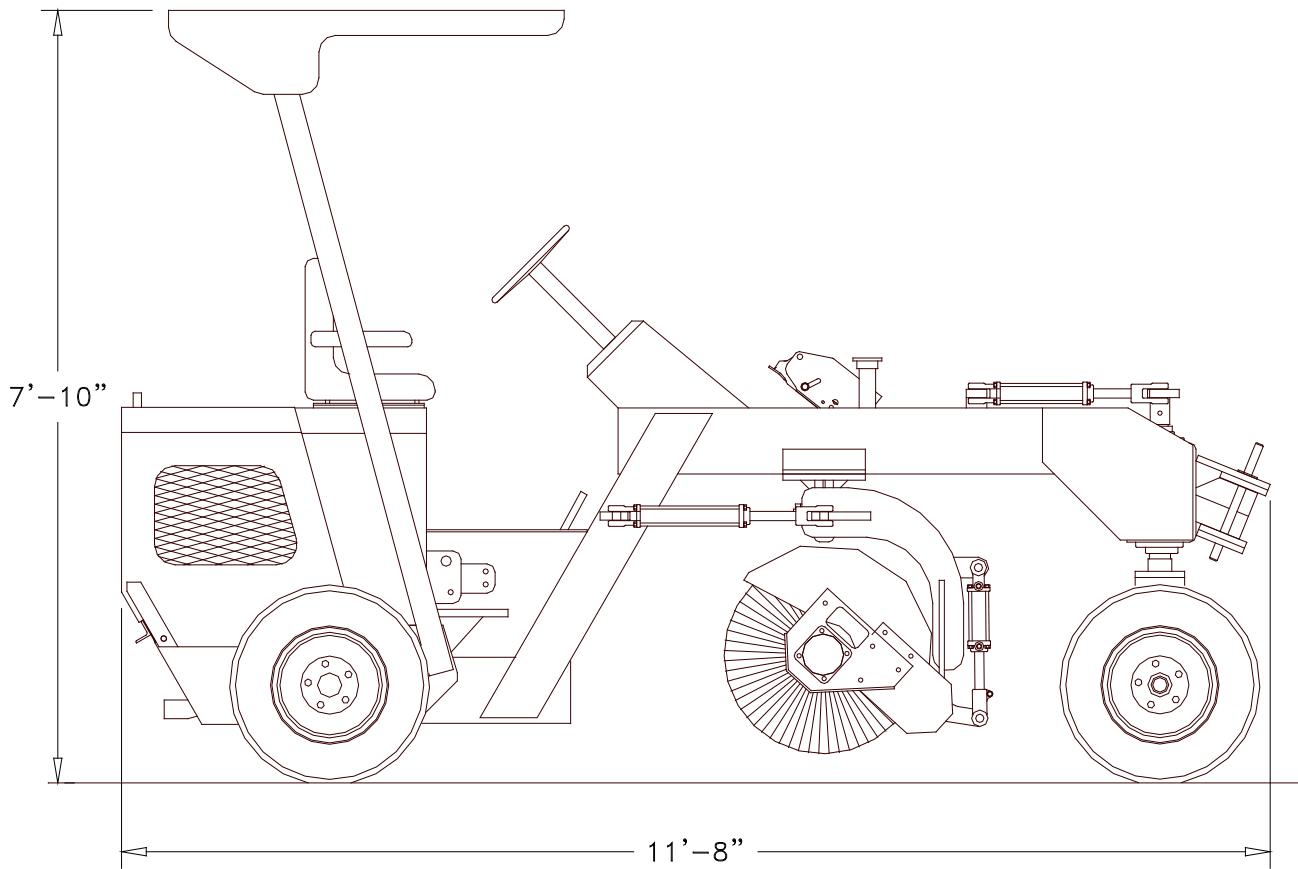

Hydraulics Specifications	
Propel Pump - closed circuit variable	
Model 4281767	Series 42
displacement max	1.71 cir
rated speed	3400 rpm
max speed	3750 rpm
min speed	500 rpm
case pressure - cts	50 psi
case pressure - max	150 psi
system pressure - cts	3000 psi
system pressure - max	5075 psi
inlet vacuum - cts	6 in Hg
inlet vacuum - max	24 in Hg
charge pressure setting	290 psi
system pressure setting	2755 psi
approximate flow @ 2400 rpm	16 gpm
Propel motors (2 per machine)	
Model 151H1054	OHM 315
displacement	19.3 cir
rated speed	235 rpm
max speed	285 rpm
system pressure - intermittent	1000 psi
system pressure - max	1750 psi
system pressure - peak	2100 psi
Broom core motor	
Model 151-6436	OMRW 250
displacement	15.3 cir
rated speed	240 rpm
max speed	300 rpm
system pressure - intermittent	1160 psi
system pressure - max	1600 psi
system pressure - peak	2900 psi
Steering unit	
Model 150L0139	OSPM 80
displacement	4.88 cir
inlet pressure max	1813 psi
tank return pressure max	290 psi
L, R line pressure max	2610 psi
fluid flow max	1.9 to 5.3 gpm
Broom rotation valve	
inlet pressure - max	3000 psi
max oil flow	20 gpm
Broom tilt/lift valve	
displacement	19.0 cir
pump rate pressure	4000 psi
input speed maximum	3400/600 rpm
max outlet pressure - primary	1500 psi RV setpoint
controlled primary flow	3.0 gpm

START UP & PROPELLING



CAUTION

Persons should ride in the seat properly wearing their seat belt whenever the vehicle is moving or in the vicinity of other moving vehicles. Otherwise, they are much more likely to suffer serious bodily injury in the event of sudden braking or a collision.

When using the seat belts, observe the following:

- Be careful not to damage the belt webbing or hardware. Take care that they do not get caught or pinched in the seat.
- Inspect the belt system periodically. Check for cuts, fraying, and loose parts. Damaged parts should be replaced. Do not disassemble or modify the system.
- Replace entire belt assembly (including bolts) if it has been used in a severe impact.
- Replace belt assembly after 3 years of use and 5 years of manufacture.

This model of broom is hydrostatically driven. Motion is achieved by depressing the foot pedal on the floor board to the right of center. Letting the foot pedal up will result in a braking action caused by the hydraulic system. This is the proper method for braking on this machine. The brake pedal on the left side of the floor board should not have to be used except in cases where the engine has died or there is a problem with the hydraulic system. To maintain operability, occasional use of brake system is advised to prevent rusting and seizure of components in place.



WARNING

BEFORE STARTING ENGINE, BE SURE PARKING BRAKE IS SET, LEFT FOOT IS ON THE BRAKE PEDAL AND RIGHT FOOT DOES NOT CONTACT THE CONTROL PEDAL. FAILURE TO DO SO COULD CAUSE UNINTENDED MOVEMENT OF VEHICLE RESULTING IN INJURY OR DEATH.

1. Turn the key switch to the start position, all the way to the right. Add fuel as necessary using the hand operated locking throttle. Release the key switch when the engine starts. Do not use ether (STARTING FLUID) in this engine, severe engine damage will occur.
2. Use the foot pedal on floor board to choose the direction of forward or reverse.
3. After the desired direction has been selected, raise engine R.P.M. to about half throttle. Release parking brake. Slowly depress control pedal and adjust the engine to the desired travel speed. Speed can also be varied by the distance the control pedal is depressed.
4. To stop the engine, turn the key back to the center position. The parking brake must be set prior to leaving the operator's seat.

NOTICE

DO NOT REVERSE THE DIRECTION OF TRAVEL WHILE THE BROOM IS IN MOTION. THIS WILL DAMAGE THE DRIVE COMPONENTS AND VOID THE WARRANTY. THIS TYPE OF OPERATION IS CONSIDERED ABUSE.

TOWING PROCEDURES

1. Before towing this machine check the following:
 - A. The tires should be inflated to 32 PSI and be in good condition.
 - B. Any loose items on the machine should be removed or secured.
 - C. Check to see that all the lug nuts/bolts are tight on the wheels and that the wheels are in good condition.
2. The Parking Brake must always be set before starting to hook up the machine to a towing vehicle. The Parking Brake must also be set before starting to unhook the machine from a Towing Vehicle.
3. Flip switch for Hitch on Dash
4. Drive Broom behind Vehicle (Leave about 5' feet between vehicle and broom)
5. Lower hitch on to ball (Have one person guide you if possible)
6. When hitch is on, Power down with control valve (Where tire is about 6" off ground)
7. Put shaft pin in hole to secure
8. Unlock hubs on the rear wheels of the machine so that it will roll freely without turning the hydraulic motors.
9. Turn valve on tow bar to OPEN, turn valve on master cylinder (under floor plate) to CLOSED position.
10. Hook up the lights and make sure they are in good working order.
11. Hook up tow chain
12. Reverse procedure for unhooking.
13. Release the Parking Brake. Pull the machine a short distance and make sure the machines brakes are not dragging. If they are, adjust and/or repair them so that they will work effectively when needed.

Note: When the machine is to be unhooked from the towing vehicle, set the Parking Brake and proceed to unhook the machine in the same manner as it was hooked up, except in reverse order.

Note: The speed at which this machine is towed depends on conditions and the personal judgment of the individual in charge but must not exceed 45 mph. Broce Manufacturing Co. will not be responsible for neglect or poor judgment at any time during machine operation and/or towing of the machine.

OPERATION OF THE SWEEPING CORE

All functions of the sweeping core are hydraulically operated. Two control valve handles are mounted to the right of the operator's seat for controlling these functions. The Joystick controls the core height up down and the right and left angle of Broom. The handle beside it controls the operation of the core motor. Turf Boss and machines with variable brush speed have brush controls on the dash panel.



RAISE / LOWER / FLOAT DETENT

To raise the core, move the Joystick to the back, "RAISE," position until the core is raised all the way. The handle will return to the hold position and core height will be maintained. To lower the core during normal sweeping conditions, move the Joystick to the front, "FLOAT" position. The "FLOAT" position will allow the core to maintain the ideal contact while allowing it to float over bumps or contours in the surface. This valve is equipped with a feature called "POSITIVE DOWN PRESSURE." It should only be used under the heaviest sweeping conditions. The down pressure adjustment is located between the hold position and the float detent. To adjust the core height downward, slowly move the handle from the hold position to the

lower position. The core will begin to move downward. Release the handle when the desired height has been achieved.

NOTE: The operator must maintain continuous adjustment on the core while the down pressure option is being used. This feature does not allow the core to float over contours in the surface. Therefore, the operator must constantly make these adjustments. If the broom core is forced to close to the ground, the bristles will not have the “flicking” action which is necessary to do a proper sweeping job. This is why the float is recommended during all but the heaviest sweeping conditions.

IMPORTANT: OVER USE OF THE POSITIVE DOWN PRESSURE FEATURE WILL CAUSE EXCESSIVE WEAR AND SHORTEN THE LIFE OF THE BROOM.

RIGHT / LEFT ANGLE

The core may be set at any angle from 40° left to 40° right. Move the Joystick to the right and it moves the core towards the right rear wheel, likewise for the left. Release the handle when the desired angle is achieved.

BROOM ON / BROOM OFF/BROOM SPEED

The core motor is activated with the handle to the right and is moved to the front, “ROTATION ON” position and turned off when the handle is moved back, “ROTATION OFF” position. Turf Boss machines have variable brush speed controlled by a dial on the dash panel.

SWEEPING TIPS

1. If the broom starts to hop or bounce, the propelling speed is too high. Slow the machine down, but maintain high engine speed. This will allow you to do a good job on the first pass and you will not need to go over it again.
2. In areas where the dirt is caked, try to clean the sweeping surface by going over it a second or third time. If this does not clear the dirt, use the Positive Down Pressure feature, although in most cases, the float position will yield the best results.
3. When changing the direction of travel, for example, backing up to sweep a spot which was not cleared the first time, always allow the machine to come to a complete stop before moving the shift lever in the opposite direction. This will help eliminate break downs and costly down time.
4. If the dust cloud becomes so thick that your vision is obscured, use the water sprinkling system or stop the machine until the dust clears. If possible, angle the sweeper so that the dust and debris is swept downwind.
5. Always wear eye protection, hearing protection and dust mask for respiratory irritants.



WARNING

OPERATOR MUST BE AWARE OF ANY PEOPLE OR PROPERTY WHICH MAY BE IN THE PATH OF FLYING OBJECTS CAST BY THE ROTATING BRUSH. FLYING OBJECTS CAN CAUSE INJURY OR DEATH.

EXTENDING BRUSH LIFE

BRUSH DOWN PRESSURE

Most problems of rapid wear, bristle breakage and loss are attributed to excessive down pressure. If the proper down pressure is used, the sweeping efficiency will improve and bristle life will be extended considerably. More down pressure does not give a result of better sweeping. The broom gets its sweeping action by the flicking action of the bristles.

Broce Brooms are equipped with a float detent control valve. This function should be used as often as possible for optimum sweeping and longer brush life.

When too much down pressure is used, the side of the bristle is in contact with the working surface and very little flicking action is present to give a good clean sweep.

Set broom down pressure to maintain sweeping pattern as shown, approximately 5-6 inch width.

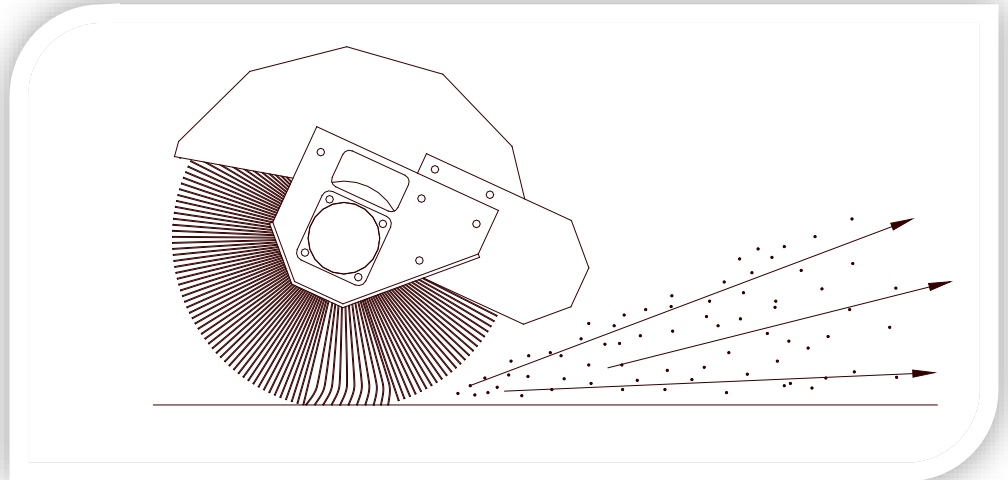

KEEPING BROOM LEVEL

Running the broom core out of level will result in a poor sweeping job and a shortened wafer life. Check the broom core for levelness every day it is to be used.

There are three things to look for if the broom core is not level.

1. Make sure both of the rear tires are inflated to the same pressure. Both rear tires should be the same brand and size to help in keeping the machine level.
2. Check the frame and make sure it is not bent.
3. Make sure the hanger bearing hub bolts are tightened evenly and the hub bearings are adjusted properly.

PROPER GROUND SPEED

Rotary sweepers work best when they use a flicking action of the bristles. The broom can sweep debris to a depth of $\frac{1}{2}$ the diameter of the brush or to the point where the frame or a shield is in contact with the debris and causes a restriction in the natural sweeping process. If the ground speed is too fast the debris may build up in front of the brush causing a wind row effect. This wind row effect will put excessive side pressure on the bristles and they will break off at the metal ring that holds them in place.

Always sweep at a brush rotation speed that is high enough and a ground speed that is low enough to discharge the debris effectively and result in a clean sweeping job.

MACHINE OPERATION AND SAFETY GUIDELINES

1. Read all decals and manuals before starting and/or operation this machine.
2. Do not operate or make any adjustments or repairs to the machine if parking brake will not hold machine from rolling. If the parking brake will not keep the machine from rolling adjust, repair or replace it before operating, adjusting or repairing the machine.
3. Always set parking brake before starting and after stopping engine on the machine. The parking brake should be set each time the operator disconnects his seat belt and leaves the operating position.
4. Always wear appropriate protective eye wear while operating, adjusting and servicing this machine and while working within 100' of this machine.
5. Do not operate this machine if any person is within operating range of this machine and if any person within 100' of the machine is not wearing appropriate eye protection and safety attire.
6. Always disengage both rear wheel lockouts before any adjustments or repairs are made and before towing machine.
7. Do not make operational adjustments or repairs to this machine with the machine running if the operator is not in the operator's seat with the seat belt fastened, with the parking brake set and with both rear wheel lockouts disengaged.
8. Before starting this machine, always check for any kind of maintenance problem that will damage machine while using.
9. Always follow industry accepted safety practices while operating or making any repairs and adjustments to this machine.
10. Do not tow this machine with any vehicle that does not meet or exceed all federal, state and local laws for vehicle GVW, trailer hitch and lighting requirements for all of the states in which you operate this machine.
11. Do not operate this machine when any person is within 100 feet of the discharge area of the sweeper broom.
12. Do not change direction of this machine from forward to reverse or reverse to forward before first coming to a complete stop.
13. Tow this machine only when the front wheel has sufficient clearance between the tire and the ground when hooked up to a towing vehicle. Be particularly cautious when going through dips and ditches.

MACHINE OPERATION AND SAFETY GUIDELINES

14. Use and attach only those Tow-Bar safety chains as recommended by federal, state and local laws.
15. Do not start, service, operate or make any adjustments to this machine before you have read and fully understood this entire manual.
16. Familiarize yourself with all operation and safety decals before operating this machine.

OPERATION & SAFETY DECALS

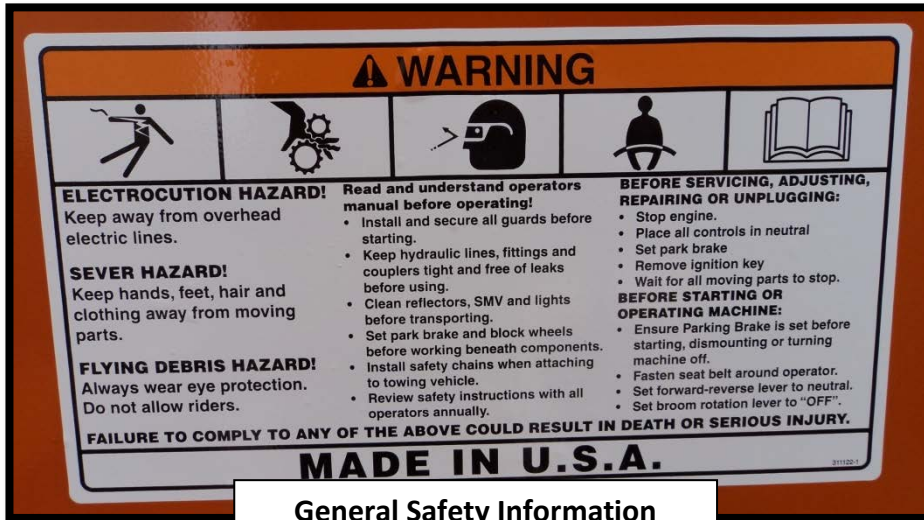

General Safety Information



Engine Fan Sever Hazard



Off-Highway Vehicle Statement



Hydraulic Oil

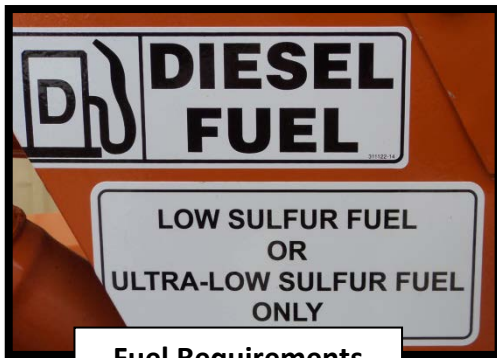

Fuel Requirements



Tie-Down Points



Flying Object Warning



Backup Alarm



Antifreeze Requirements

OPERATION CONTROLS

Standard BB-250 Model Dashboard Controls



OPERATION CONTROLS

Turf Boss™ Model Dashboard Controls



OPERATION CONTROLS

Parking Brake and Vehicle Travel

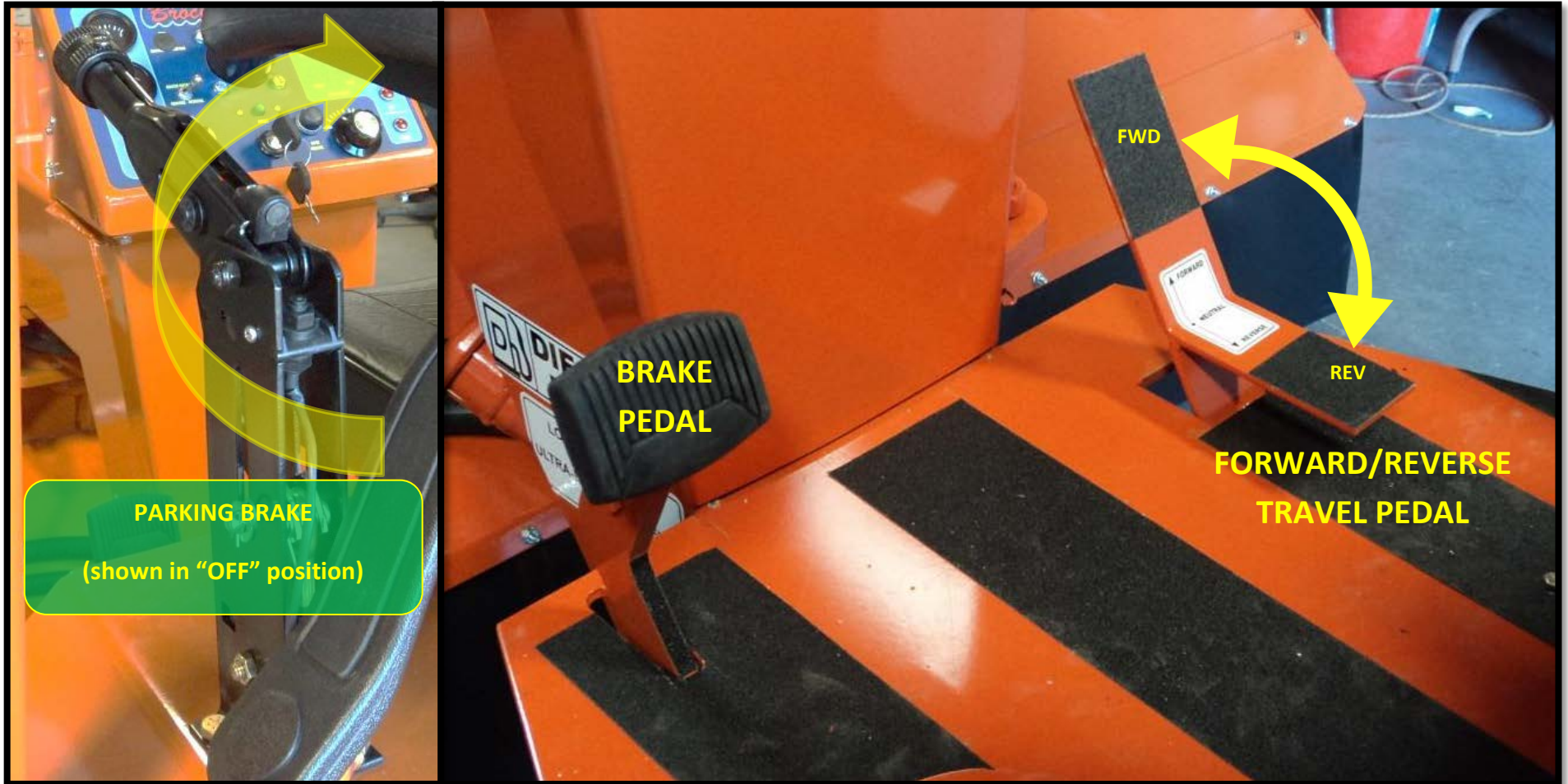

OPERATION CONTROLS

Standard BB-250

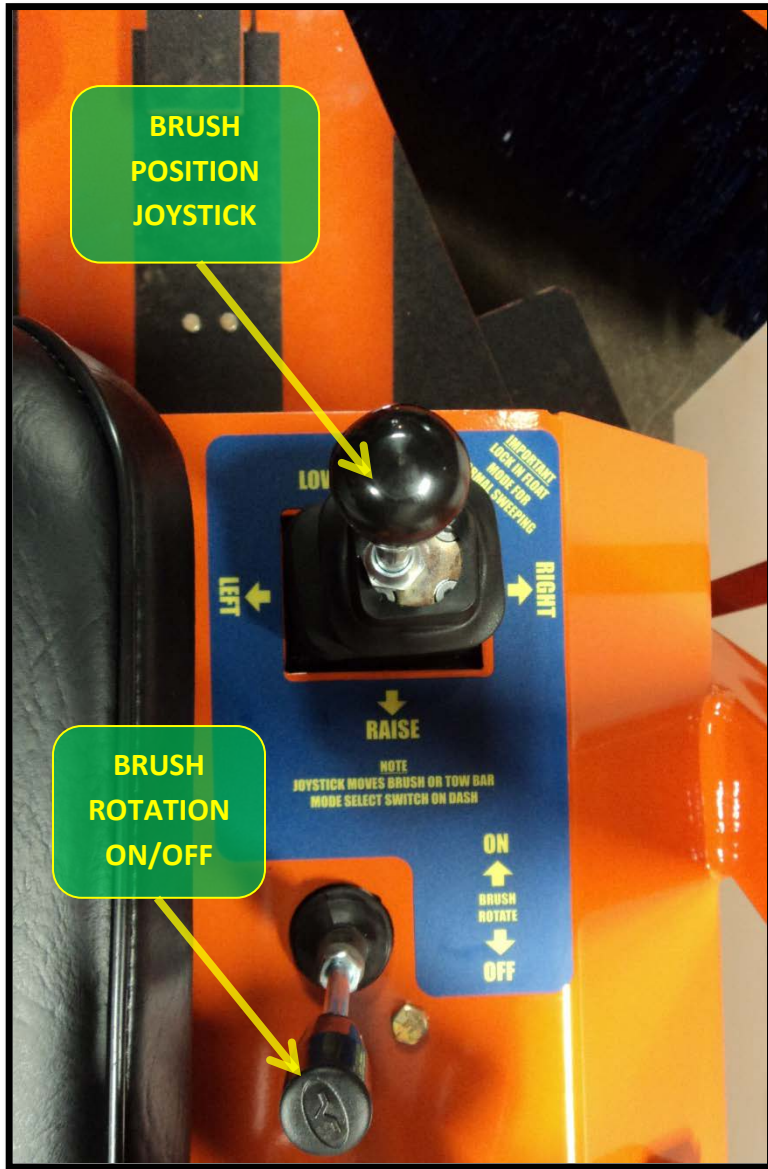

Turf Boss™



MACHINE SERVICE AND SAFETY GUIDELINES

1. Read all decals and manuals before starting and operating this machine.
2. Do not operate or make any adjustments or repairs if the Parking Brake does not hold machine. Repair the Parking Brake first, before making any other repairs or adjustments to this machine.
3. Always set Parking Brake before starting and after stopping engine on this machine.
4. Do not operate this machine if any person is within operating range of machine and if any person within 100 feet of machine and is not wearing appropriate eye protection and safety attire.
5. Always disengage both rear wheel lockouts before making any adjustments or repairs to the machine and before towing machine.
6. Do not make operational adjustments or repairs to this machine with the machine running if the operator is not in the operator's seat with seat belt fastened, with Parking Brake set and with both rear wheel lockouts disengaged.
7. Before starting this machine, always inspect both (2) Variable-Speed-Pedal return springs located on the right side of the machine below the floorboard. Do not start or operate this machine if both (2) Variable-Speed-Pedal return springs are not in place and functional.
8. When servicing any component of the engine starting circuit on this machine including the battery, always DISCONNECT THE NEGATIVE CABLE FIRST.
9. Always wear protective eye wear and safety attire when servicing battery.
10. When connecting battery cables always CONNECT THE POSITIVE CABLE FIRST.
11. Do not "JUMP START" this machine under any circumstances. If the battery power is low, remove the battery and replace it with a battery that has a full charge.
12. Under no circumstances is ether (STARTING FLUID) to be used when trying to start the engine in this machine. Severe engine damage will occur if ether is used.
13. Always follow industry accepted safety practices while operating or making any repair and adjustments to this machine.
14. Do not tow this machine with any vehicle that does not meet or exceed all federal, state and local laws for vehicle GVW, trailer hitch and lighting requirements for all of the areas in which you operate this machine.
15. Tow this machine only when the front wheel has sufficient clearance between the tire and the ground when hooked up to a towing vehicle. Be particularly cautious when going through dips and ditches.
16. Use and attach only those tow-bar safety chains as recommended by federal, state and local laws.
17. Do not start, service, operate or make any adjustments to the engine or the machine itself before you have read and fully understood all of the manuals.

LUBRICATION AND MAINTENANCE

1. Grease two **steering shaft** bearings at the front of the machine every day.
2. The **front wheel bearings** should be cleaned and packed every six months.
3. The **tires** on the front and rear of the machine should be kept at 32 psi and should be checked on a daily basis. When a tire (or tires) needs to be replaced, make sure the replacement tire is the same type and height as the remaining tire (tires) on the machine. This will keep the sweeping core level.
4. The **battery** should be checked once a month. Use distilled water only to bring the fluid level up to the required height. Keep battery post and cables clean. Battery requirements are: 12v, 70AH or equivalent.
5. The **radiator** should be checked for dirt build up every 4 to 8 hours. Use water or compressed air directed from the engine side of the radiator to remove excess dirt. A mixture of 50% water and 50% permanent antifreeze should be used in the radiator thru the entire year. Check the mixture and fluid level at least once a week. The fluid level should be ½ full on the side of the over flow tank.
6. **Engine oil** should be checked once per day. Engine oil type should be: 10w30, MIL-L-21046 or CD (API spec.) equivalent or above. Oil pan capacity is 7 quarts. The oil and oil filter should be changed after the first 50 hours and every 150 hours thereafter. All other filters, air, spin-on fuel and in-line fuel should be changed every 150 hours. Pre-Cleaner bowl at the top of the air inlet tube should be emptied and cleaned daily. Use only diesel fuel.
7. The **fuel tank** should be drained once a year. The fuel tank drain is located in the back of the fuel tank.
8. The **water system** (for dust control) should be inspected daily. Clean the water filters, the spray nozzles and the screen inside the nozzle head daily. Empty tanks daily to prevent algae build up.
9. The **wheel lock-out hub** oil level should be checked every three months. Remove the female hex plug on front or back of the housing to check, the oil level should be up to this hole. If oil needs to be added use a 10w40 non-detergent motor oil. Capacity of this hub is approx. ½ pint or 8oz.
10. **Hydraulic oil** should be checked daily. **This unit requires the hydraulic tank to be completely or nearly full for proper function.** Oil should be at least to the full mark on the gauge at the right side of the hydraulic tank. Low hydraulic will result in hesitation of core function and possible pump cavitation. Change hydraulic oil every six months or as needed. Hydraulic oil type: Dyna-Plex 21C Cursa or any Hydro-46 viscosity oil. Change both spin-on hydraulic filter (under hood to the left of the engine) and the high pressure filter (under the hood, to the right and forward of the engine) every three months or every 500 hours, whichever comes first.

BRAKE INSPECTION AND SERVICE

This machine is equipped with dynamic hydraulic braking, conventional hydraulic brakes and a mechanical Parking Brake.

The dynamic hydraulic braking will be in operation any time that the engine is running. When the foot pedal is released, the hydraulic system provides enough braking action that the conventional foot pedal brake should not have to be used. If the dynamic braking is not sufficient to stop the machine, check for hydraulic leaks and low hydraulic fluid level.

The Parking Brake should be used every time the operator leaves the operators seat, whenever the machine is being started, when the machine is being prepared for towing and/or whenever any repairs or adjustments are being made.

When the machine is being towed, the coupler at the end of the hitch will activate the mechanical brakes anytime the driver of the towing vehicle applies his brakes.

The operation of the brakes should be tested daily. Daily before this machine is to be operated, check the feel of the brake pedal. The pedal should be firm when depressed. If the pedal feels spongy, there may be air in the system. If the brake pedal goes all the way to the mechanical stop, there is a leak in the system, the reservoir is low on fluid and the brake shoes either need adjusting or need to be replaced. If the brakes don't feel right or do not operate correctly they should be serviced before using this machine.

The location for checking and adding brake fluid is the coupler cylinder on the end of the Tow Hitch. When checking and adding brake fluid to the braking system, lower the Tow Hitch in front of the machine, as if you were preparing it to be towed. This will put the cylinder reservoir in the best posture for checking and filling of brake fluid. Check the fluid level periodically, especially if the brake lines show signs of leakage. If it becomes necessary to add or change the brake fluid, use a fluid with a DOT3 rating. Inspect brake lines every 50 hours (maximum) for leaks and/or damage. Replace brake hoses every two years.

When checking the brake fluid level or bleeding the brakes, do so at the end of the Tow Hitch. Lower the Tow Hitch in front of the machine, so that the reservoir in the ball coupler is relatively level. Use a wrench on the end of the ball coupler to pump fluid from the reservoir through the braking system. From here on follow the standard automotive procedures for bleeding brakes.

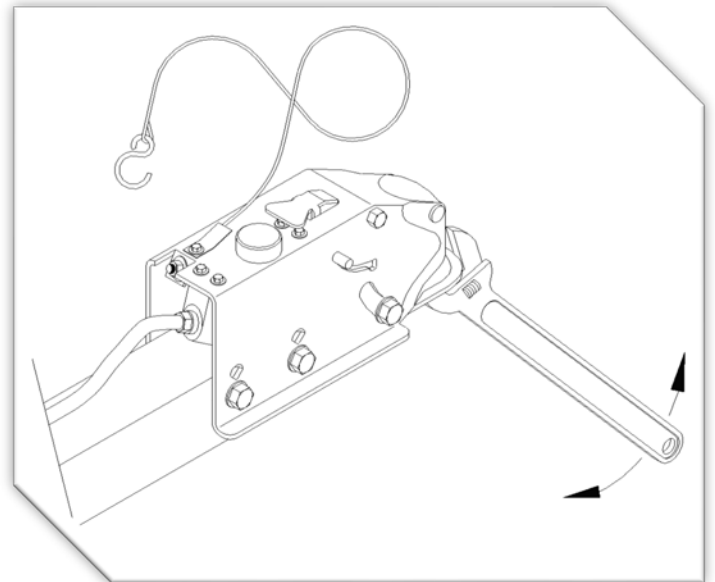

ENGINE

The normal engine operation and maintenance procedures are covered in a separate manual, which is furnished by the engine manufacturer. We do suggest, however, due to the dusty conditions in which these machines operate, that engine fan inspection and replacement should be accomplished more frequently than the engine manufacturer may suggest. Inspect the fan every 300 to 400 hours. The dust in the air will eventually erode the fan blades to a condition that may cause a safety hazard or an operational failure. Replace the fan if it is deteriorated to the point that it may not provide enough air movement for cooling or when the blades become too sharp or too chipped to safely perform maintenance around. This erosion is considered to be a normal wear item on this type of machine.

STORAGE

The storage of this machine follows the pattern of any construction equipment. We do however recommend that when leaving a machine out in the weather that has wire as part of the core and it is exposed to the weather, a light spray of oil be applied to retard rusting.

Do not store polypropylene (poly) brushes in direct sunlight! Polypropylene is chemically affected in direct sunlight. After prolonged exposure to sunlight, the material can deteriorate and will greatly shorten the life of the bristle.

Do not let this machine sit with the sweeping core lowered with the weight on the bristles. This will cause a flat spot on the brush and make it bounce when in use. To avoid this, use the center "OFF" or core-locked position on the dash-mounted joystick mode switch.

To prevent rust on the hydraulic cylinder piston rods, store in the retracted position so the rods are not exposed to the elements.

BROOM WAFERS

Poly wafers are used in normal dry sweeping conditions: dirt, sand, leaves and other light debris. These types of jobs will give the wafers their longest life. Poly is recommended for most applications due to their increased flicking ability and is more economical to replace.

A combination of **½ poly and ½ wire wafer** is not recommended except in conditions where aggressive sweeping is needed. In most cases the standard all poly brush will be adequate. The wire wafers will wear faster than the poly and cost much more to replace. Wire has sharp tips for cutting action and can reach down into cracks and crevasses better than poly. The sharp ends of the wire cut through ice and snow faster than poly wafers. We recommend no more than a 2" down pressure pattern be used with wire wafers or a combination of poly and wire to prevent breakage of the bristles. If too much down pressure is exerted on the bristles they will flex too much and break off close to the wafer base, leaving the bristles on the pavement. Excessive down pressure reduces broom life considerably.

The **life span of brush wafers** is directly related to the way they are used. When properly used the brush wafer life can be extended by 50 to 100 hours.

SERVICE PARTS

FRAME AND ASSOCIATED PARTS

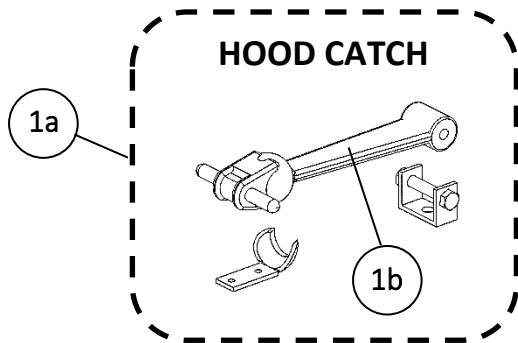
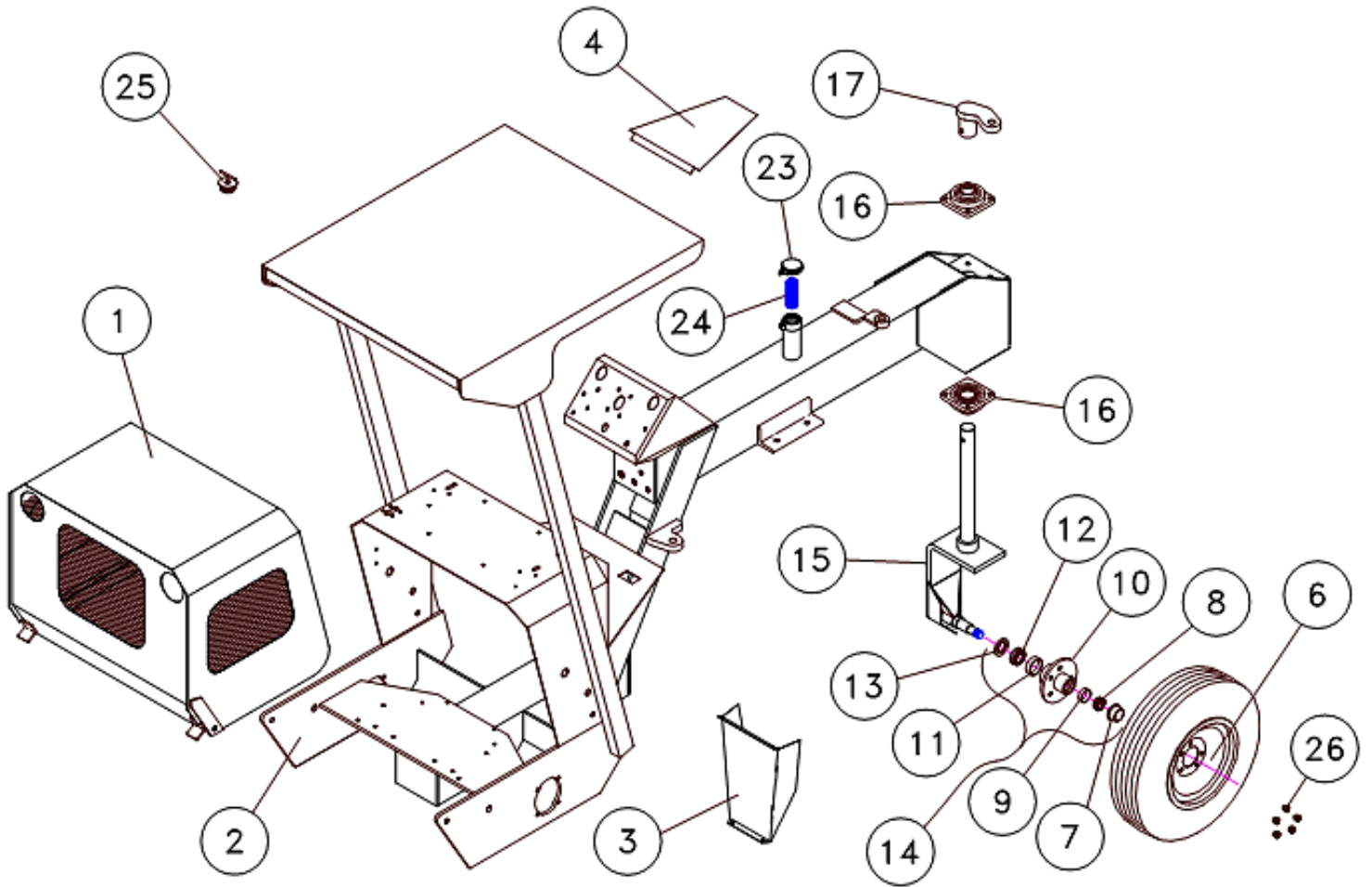

FRAME AND ASSOCIATED PARTS

Ref#	Part #	Qty	Description
1	850131	1	Hood
	850693		Hood (Turf Boss™)
1a	VF-319-RA	2	Hood Catch Assembly (Complete)
1b	VF-803-R	2	Hood Catch (Rubber Strap only)
2	850126	1	Main Frame
3	202358	1	Hydraulic Hose Shield
4	202403	1	Dash Cover
6	304058	3	Tire/Wheel 14", 5 Bolt (Standard BB-250)
	304058A		Turf Tire/Wheel 14", 5 Bolt (Turf Boss™)
7	344124	1	Grease Cap
8	344125	1	Outer Bearing Cone
9	344126	1	Outer Bearing Cup
10	see item 14	1	Wheel Hub 5-Bolt
11	344128	1	Inner Bearing Cup
12	344129	1	Inner Bearing Cone
13	344130	1	Hub Grease Seal
14	344131	1	Wheel Hub Complete (7, 8, 9, 10, 11, 12, 13)
15	850130	1	Front Wheel Support Assy. (Standard BB-250)
	850645		Front Wheel Support Assy. (Turf Boss™)
16	344132	2	Bearing 2", 4 Bolt Flange
17	850144	1	Steering Lug
23	T-702-B	1	Oil Filler Cap (Hyd. Tank)
24	344108	1	Oil Filler Screen (Hyd. Tank)
25	344183	1	Fuel cap
26	69 957B	15	Wheel Lug Nuts
29	BS-1050	1	Seat (Not Shown) W/Logo
30	C-211	1	Seat Belt (Not Shown)

HYDRAULIC TOW BAR PARTS

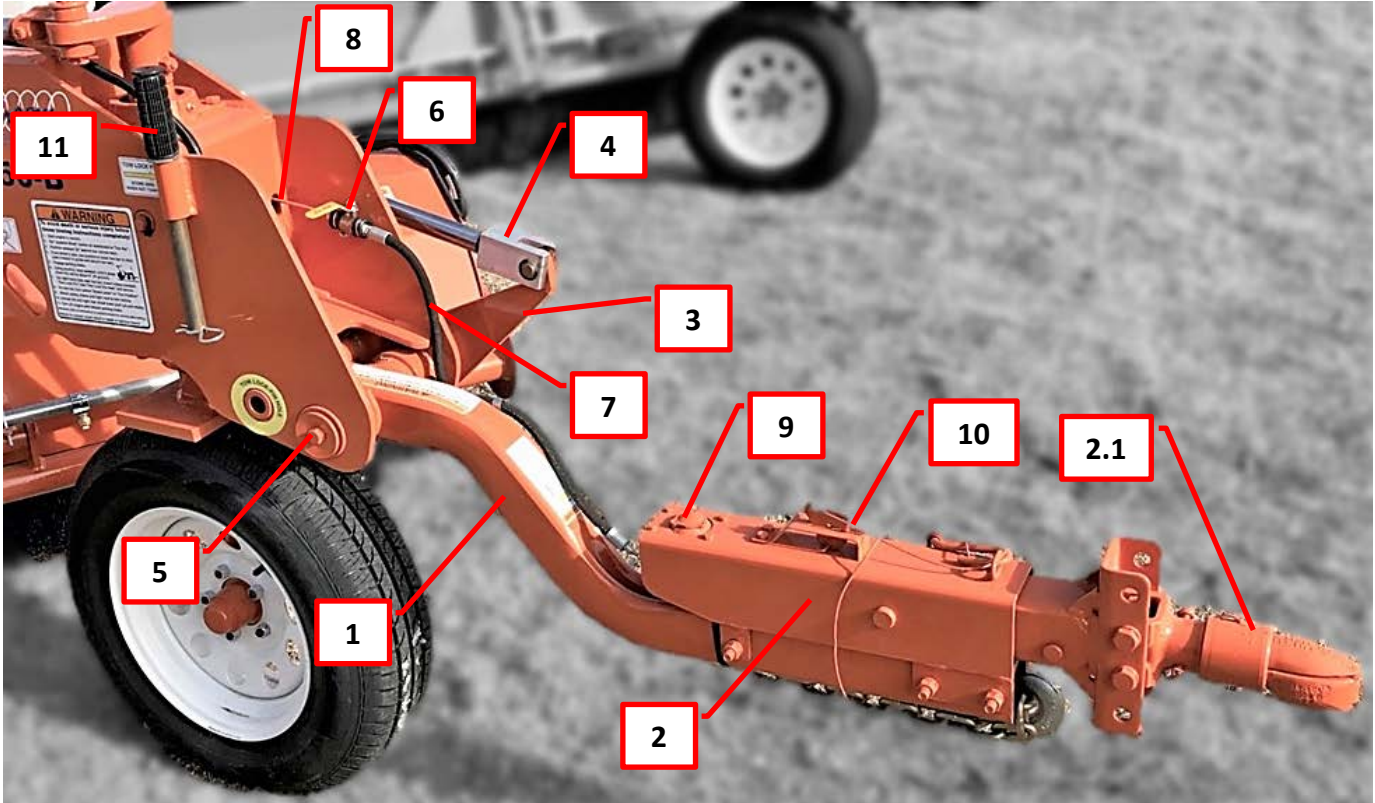

Ref #	Part #	Qty	Description
1	852584	1	Tow Bar
2	305021C	1	Surge Brake Actuator
2.1	344074A	1	2" Coupler (shown)
2.2	305021B	1	2 5/16" Coupler (not shown)
2.3	344074	1	3" Pintle Coupler (not shown)
3	852312	1	Hydraulic Lever Assembly
4	202573	1	Cylinder Rod Clevis End
5	202571	1	Hydraulic Step Shaft
6	306532	1	Ball Valve
7	305019	1	Hydraulic Hose Assembly
8	344451	1	Steel Brake Line
9	305028	1	Master Cylinder Cap with O-Ring
10	344171	1	Break-Away Cable
11	202569	1	Tow-Bar Lock Pin

HYDRAULIC TOW BAR PARTS

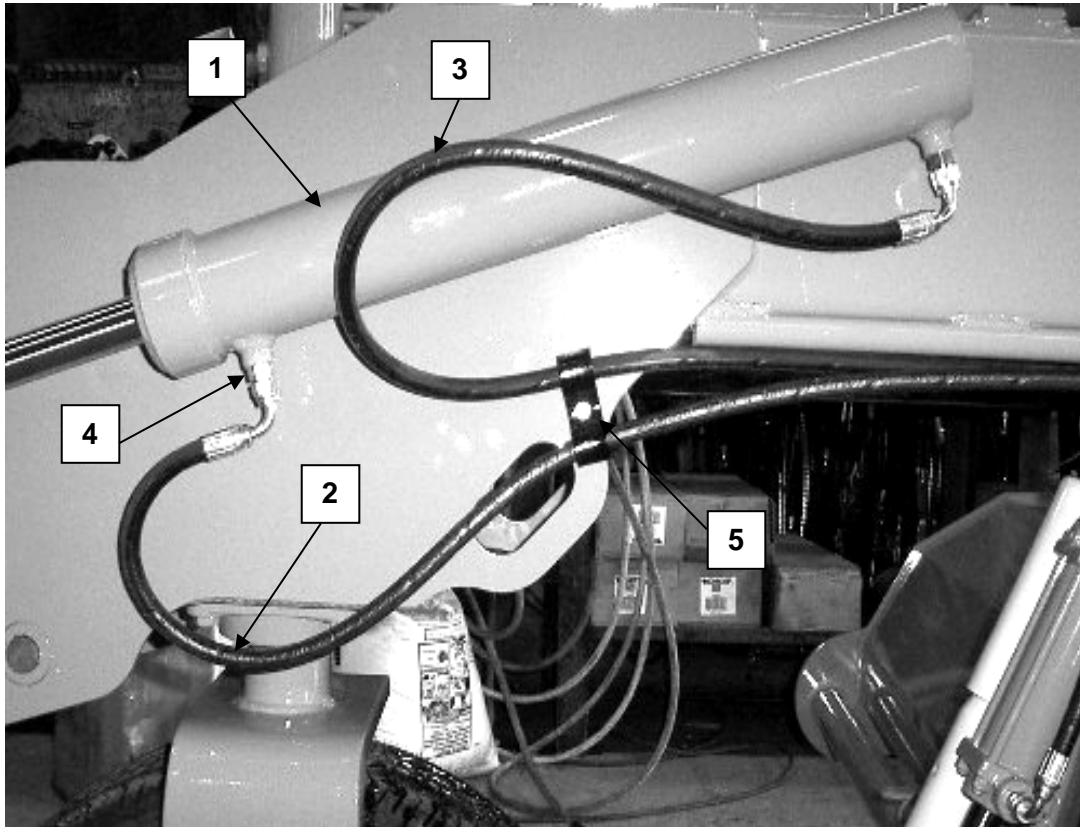

Ref #	Part #	Qty	Description
1	202575	1	Hydraulic Cylinder
2	CALL	1	Hydraulic Hose Assembly
3	CALL	1	Hydraulic Hose Assembly
4	CALL	1	Hydraulic Fitting
5	001397	1	Hose Clip

HYDRAULIC TOW BAR PARTS

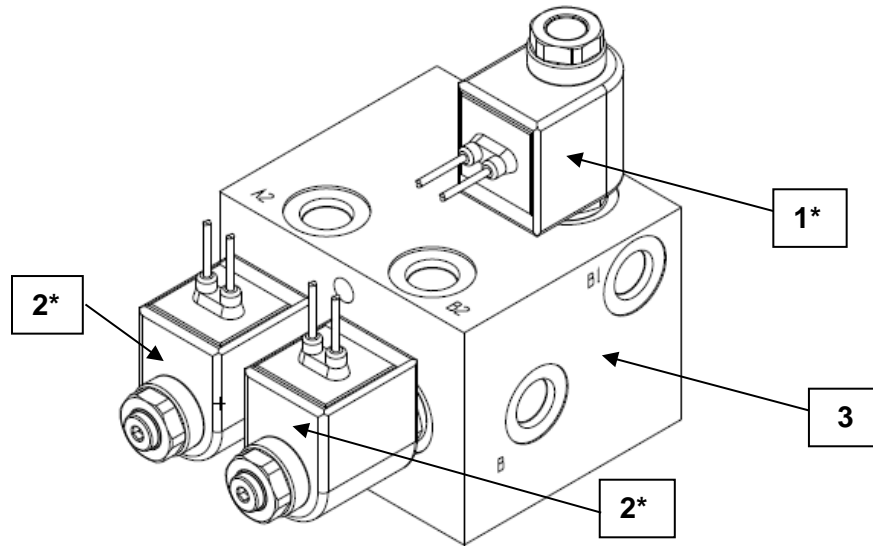

Ref #	Part #	Qty	Description
1	355028	1	Cartridge Valve
2	355027	2	Cartridge Valve
3	752213	1	Hydraulic Tow Bar Control Valve
<i>* Part includes stem and cartridge</i>			

BROOM CORE PARTS

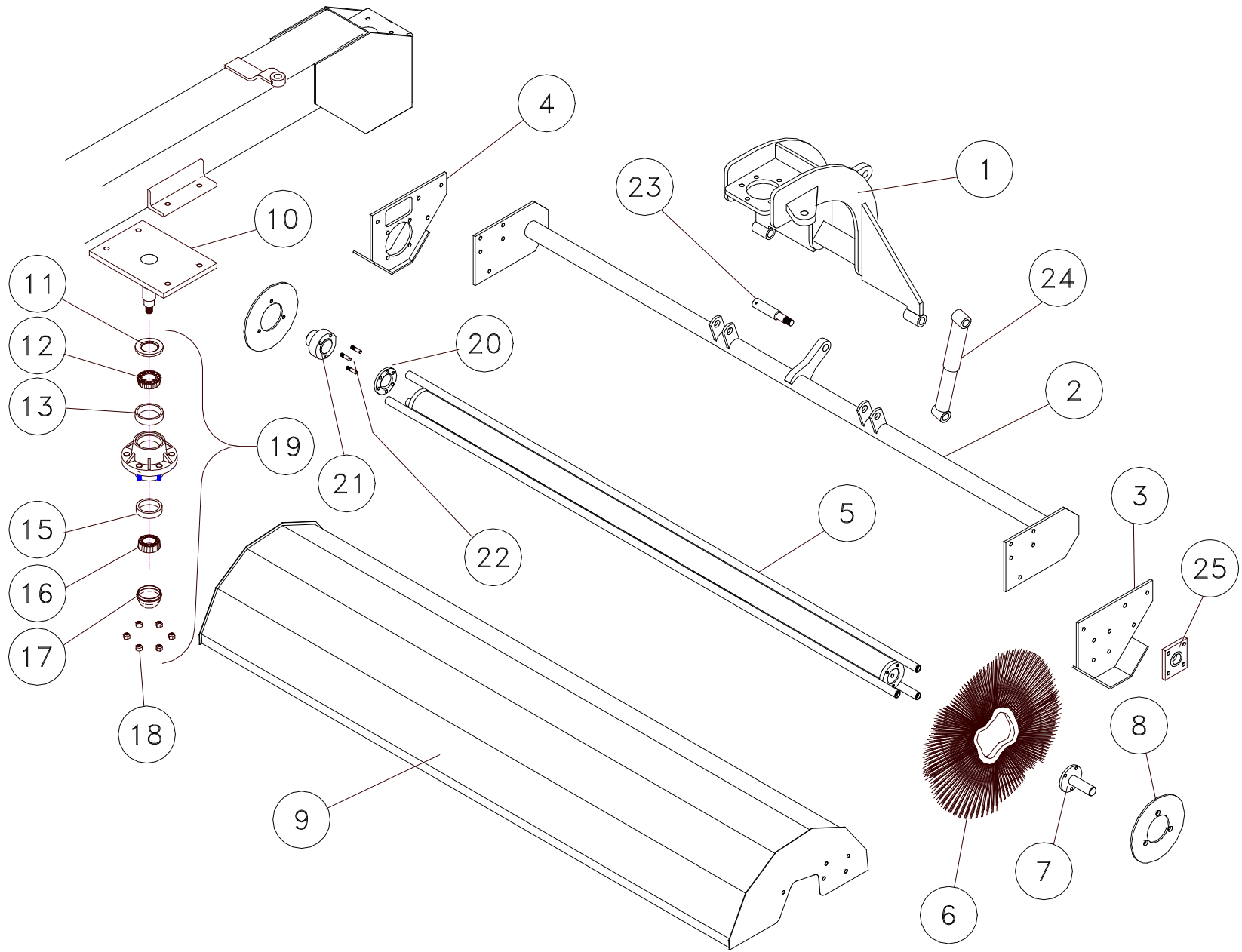

BROOM CORE PARTS

Ref	Part #	Qty	Description
1	850132	1	Core Hanger
2	850137	1	Core Support Frame
3	850671	1	Core Frame End Plate
4	850139	1	Core Motor Mount - Left Side
5	850136	1	Broom Core
6	RW-503B	1	Single Poly Wafer W/Spacer
	344145		Single Wire Wafer W/Spacer
	344137		Set - Poly Wafers W/Spacer
	344148		Set - 1/2 Poly & 1/2 Wire Wafers W/Spacers
7	850670	1	Core Drive End Shaft
8	202327	2	Core End Plate
9	850138	1	Core Shield
10	850133	1	Spindle Core Hanger
11	344110	1	Grease Seal
12	344111	1	Inside Bearing Cone
13	344112	1	Inside Bearing Cup
15	344113	1	Outside Bearing Cup
16	344114	1	Outside Bearing Cone
17	344115	1	Grease Cup
18	344116	6	Hub Lug Nut
19	344100	1	Hub Core Hanger Complete
20	502424	1	Core Drive Spacer Plate
21	344070	1	Core Motor Hub with Pins
23	201331	1	Core Shock Pin
24	344265	1	Core Shock
25	320221	1	Core End Bearing

STANDARD 250 SERIES HYDRAULICS DIAGRAM & COMPONENTS

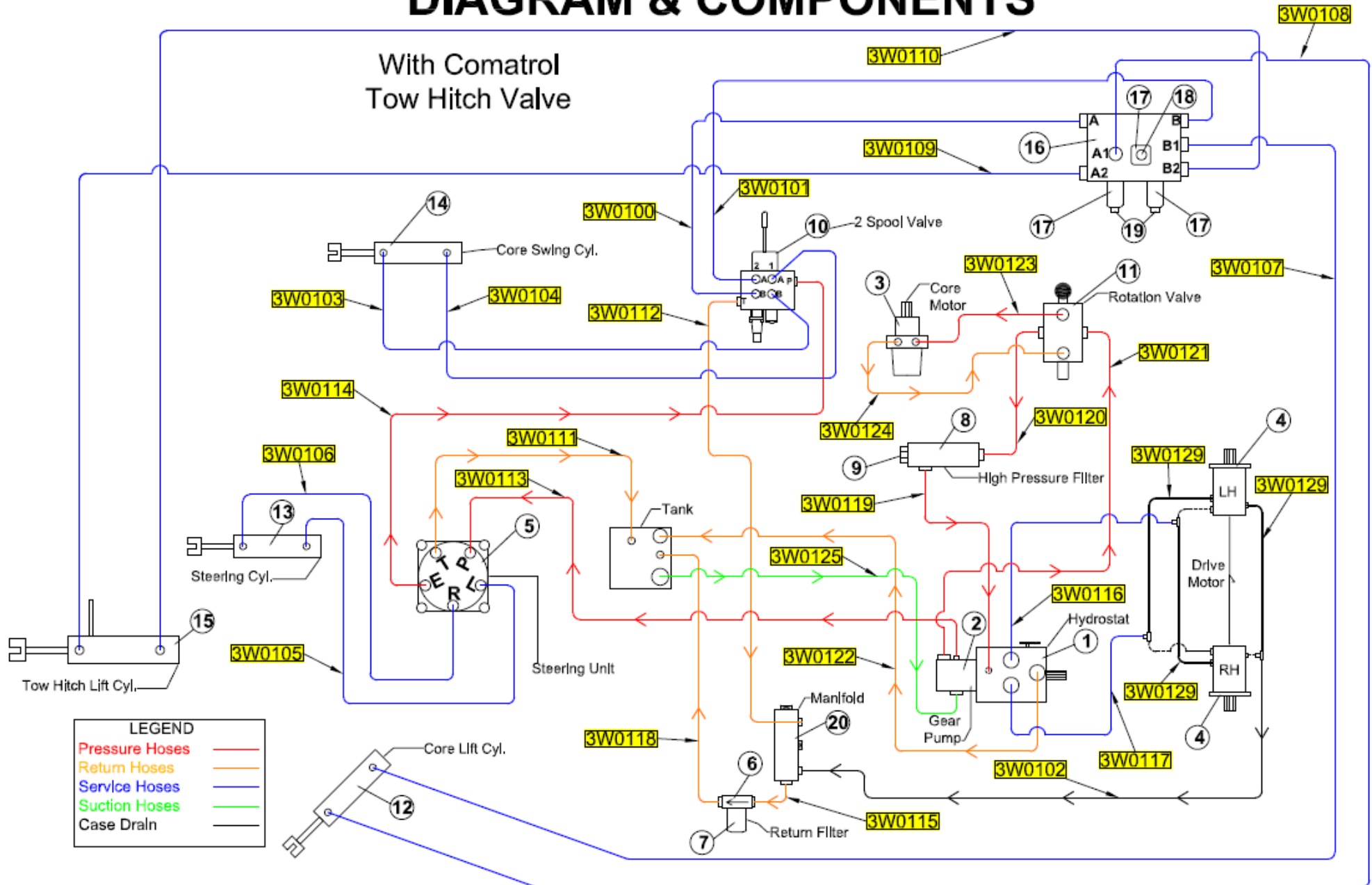

STANDARD 250 SERIES HYDRAULIC COMPONENTS

Ref	Part #	Qty	Description
1	305973	1	Variable Pump w/A-pad
2	355055	1	Gear Pump (Danfoss)
3	355051A	1	Hyd. Motor, Core Drive
4	355041	2	Wheel Drive Hyd. Motor
5	305903	1	Steering Unit (Danfoss)
6	344082	1	Hyd. Filter Head
7	344150	1	Hyd. Filter, 10 Micron
8	852251	1	H.P. Filter Housing
9	344151	1	Filter Element, H.P.
10	355030	1	2 Spool Control Valve (Hydro)
11	355013	1	Broom Rotation Control Valve (1-Spool Walvoil)
	355015	1	Handle Kit for 355013
12	204	1	Cylinder, 2 x 4, Lift
13	208	1	Cylinder, 2 x 8, Steering
14	210	1	Cylinder, 2 x 10, Angle
14.1	IC-4244	1	Seal Kit for P/N 204, 208 & 210 above
15	202575	1	Hitch Hydraulic Cylinder
15.1	355016	1	Seal Kit for P/N 202575 above
16	202580	1	Hyd, Hitch Control Valve (W/O Solenoid)
17	305983	1	Coil
18	305984	1	Block Hitch Cartridge
19	305985	2	Cartridge Valve
20	305526	1	Manifold
NOT SHOWN			
21	304092	1	Steering Wheel
22	355039	1	Seal Kit for 2 Spool Valve (Hydro)
24	305936	1	Seal Kit for Steering Unit (Danfoss)
25	305935	1	Seal Kit for Variable Pump
26	355063	1	Seal Kit for Core Drive Motor (White)
27	355064	2	Seal Kit for Wheel Motor (White)
28	550-5	1	Hydraulic Sight Glass
29	303004	1	Engine Drive Housing (Kubota Motor)
31	344252	1	Engine Drive Plate
32	344253	1	Engine Drive Hub
33	305967	1	Seal Kit for Rotation Valve

TURF BOSS™ 250 SERIES HYDRAULIC DIAGRAM & COMPONENTS

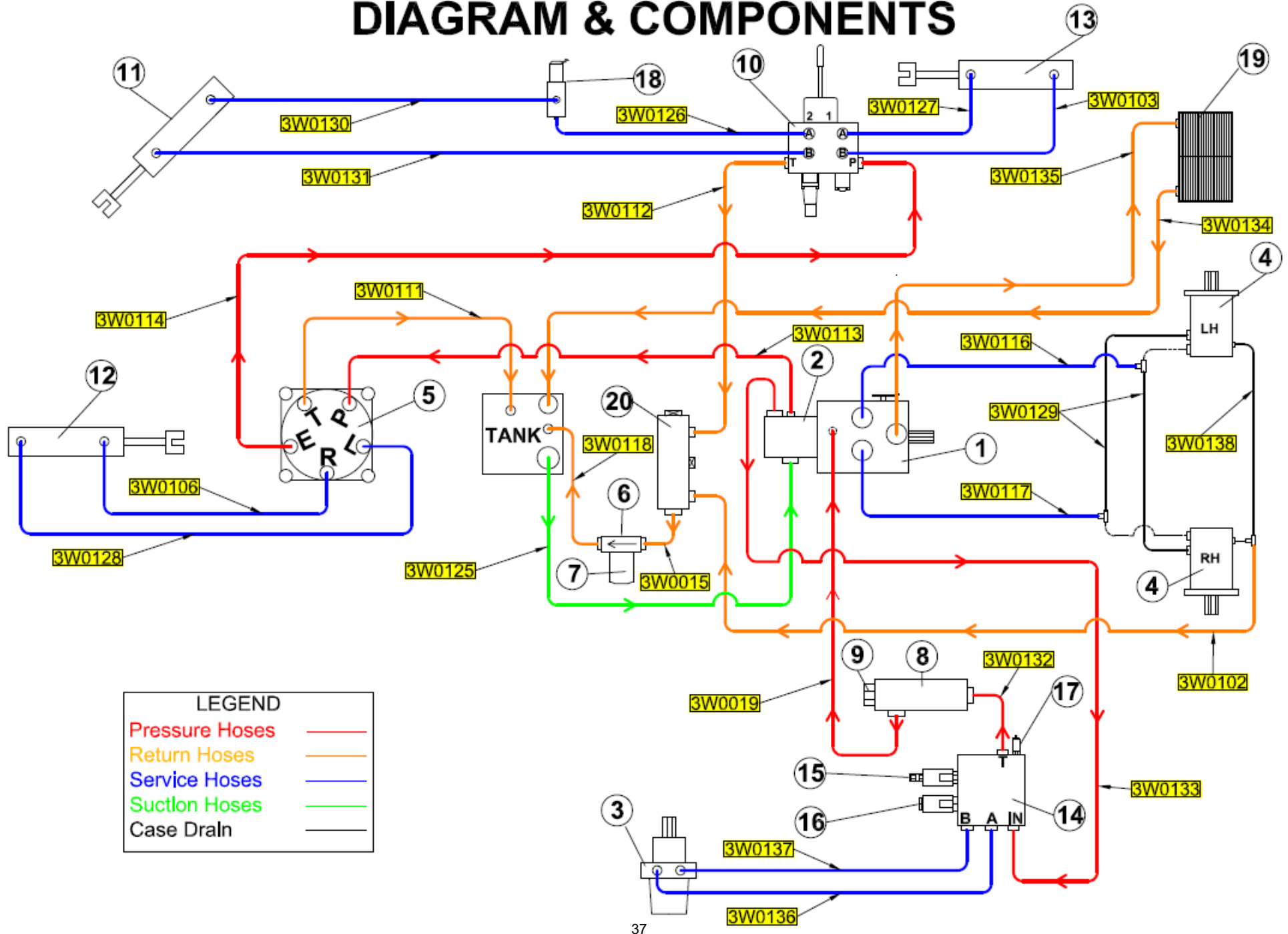

TURF BOSS™ 250 SERIES HYDRAULIC COMPONENTS

Ref #	Part #	Qty	Description
1	305973	1	Variable Pump w/A-pad
2	355055	1	Gear Pump (Danfoss)
3	355051A	1	Hyd. Motor, Core Drive
4	355041	2	Wheel Drive Hyd. Motor
5	305903	1	Steering Unit (Danfoss)
6	344082	1	Hyd. Filter Head
7	344150	1	Hyd. Filter, 10 Micron
8	852251	1	H.P. Filter Housing
9	344151	1	Filter Element, H.P.
10	355030	1	2 Spool Control Valve (Hydro)
11	204	1	Cylinder, 2 x 4, Lift
12	208	1	Cylinder, 2 x 8, Steering
13	210	1	Cylinder, 2 x 10, Angle
14	355042	1	Variable Speed w/ Reverse Manifold
15	355043	1	Proportional Cartridge
16	355044	1	Reverse Cartridge
17	355045	1	Relief
18	305763	1	Lock Solenoid
19	202677	1	Radiator
20	305526	1	Return Manifold
NOT SHOWN			
21	304076	1	Steering Wheel
22	355039	1	Seal Kit for 2 Spool Valve (Hydro)
24	305936	1	Seal Kit for Steering Unit (Danfoss)
25	305935	1	Seal Kit for Variable Pump
26	355063	1	Seal Kit for Core Drive Motor (White)
27	355064	2	Seal Kit for Wheel Motor (White)
28	550-5	1	Hydraulic Sight Glass
29	303004	1	Engine Drive Housing (Kubota Motor)
31	344252	1	Engine Drive Plate
32	344253	1	Engine Drive Hub

SINGLE SPOOL VALVE (BRUSH ON/OFF)

Ref	Part #	Qty	Description
1	355013	1	Complete Valve Assembly
2	355015	1	Handle
NS	355018	1	Seal Kit

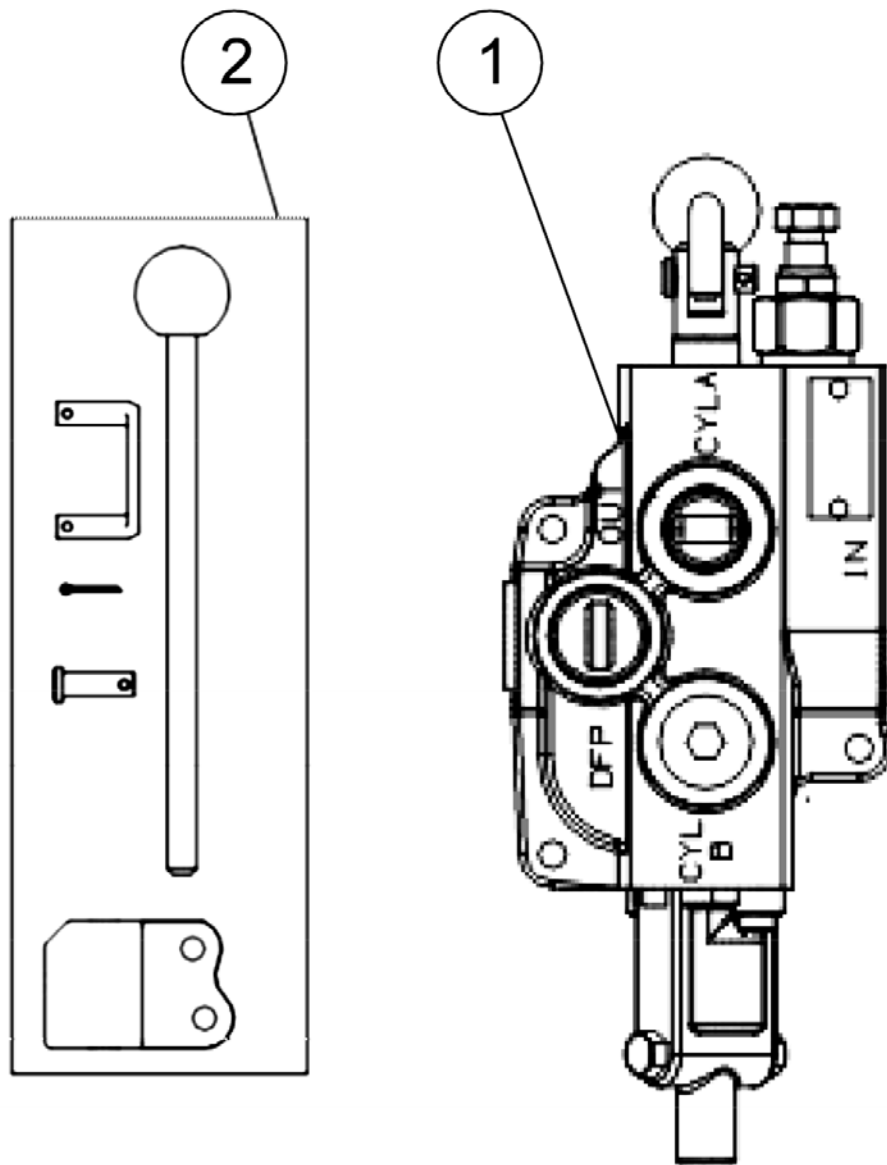

JOYSTICK VALVE ASSEMBLY

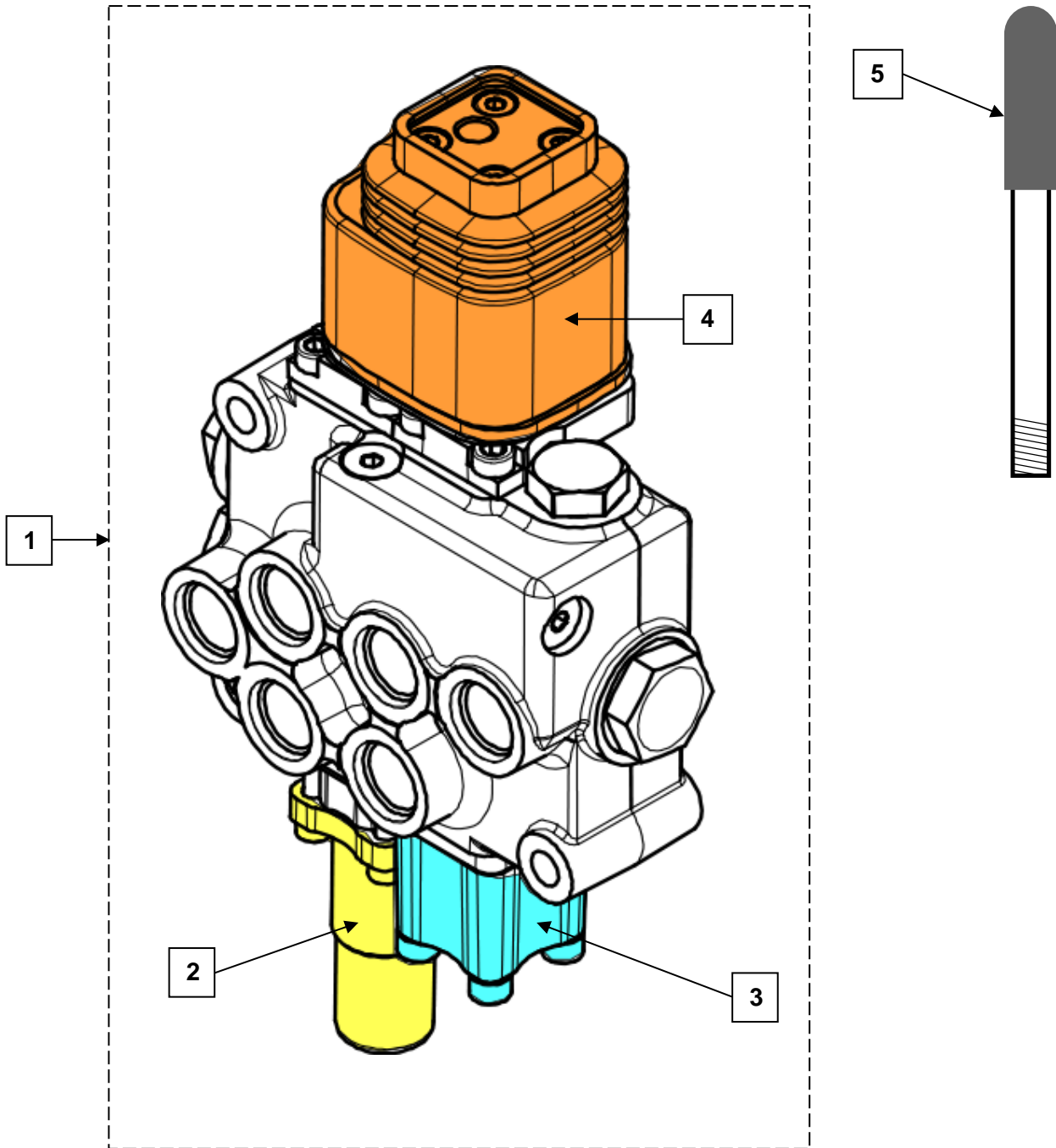

JOYSTICK VALVE ASSEMBLY

Ref	Part #	Qty	Description
1	355030	1	Complete Valve Assembly
2	355040	1	Float Detent
3	355036	1	Spring Center Detent
4	355037	1	Joystick Kit
5	355033	1	Joystick Handle/Lever
NS	355039	1	Seal Kit

BRAKE PARTS

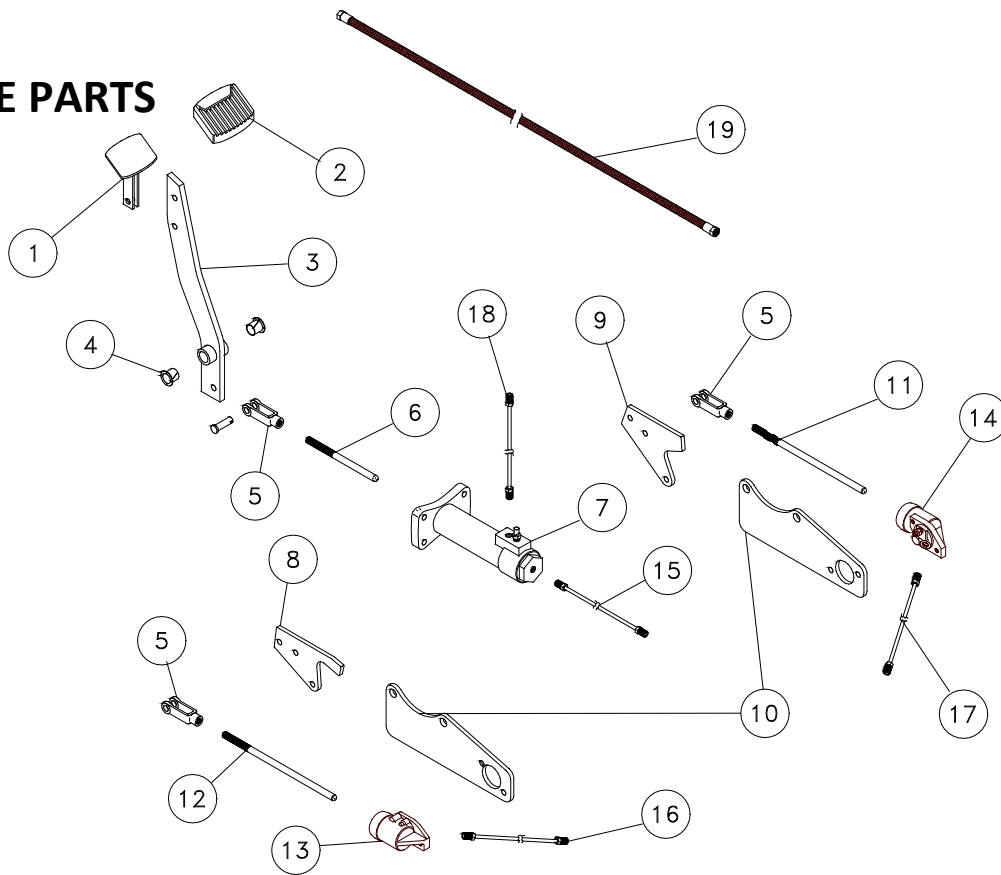

Ref #	Part #	Qty	Description
1	850153	1	Brake Pad
2	B-241-R	1	Rubber Brake Pad
3	850128	1	Brake Pedal
4	2461	2	Pivot Bushing
5	B-27084A	3	Clevis 3/8" x 3" NF
6	202674	1	Brake Actuator Push Rod
7	B-240-R	1	Master Cylinder (part may differ from picture shown)
8	202444	1	Brake Cylinder Rod Plate, Left Side
9	202443	1	Brake Cylinder Rod Plate, Right Side
10	202441	1	Brake Cylinder Plate
11	202445	1	Brake Cylinder Push Rod, Right Side
12	202446	1	Brake Cylinder Push Rod, Left Side
13	344172	1	Wheel Brake Cylinder, Left
14	344173	1	Wheel Brake Cylinder, Right
	344221	2	Wheel Brake Cylinder Repair Kit
15	344188	1	Brake Line 3/16" x 54 1/2" (actuator to tee)
16	344187	1	Brake Line 3/16" x 42 1/2" (tee to left wheel cyl)
17	344450	1	Brake Line 3/16" x 8" (tee to right wheel cyl)
18	344189A	1	Brake Line 3/16" x 88" (actuator to surge brake hose)
19	344290	1	Brake Line Hose (tow hitch)

BRAKE PARTS

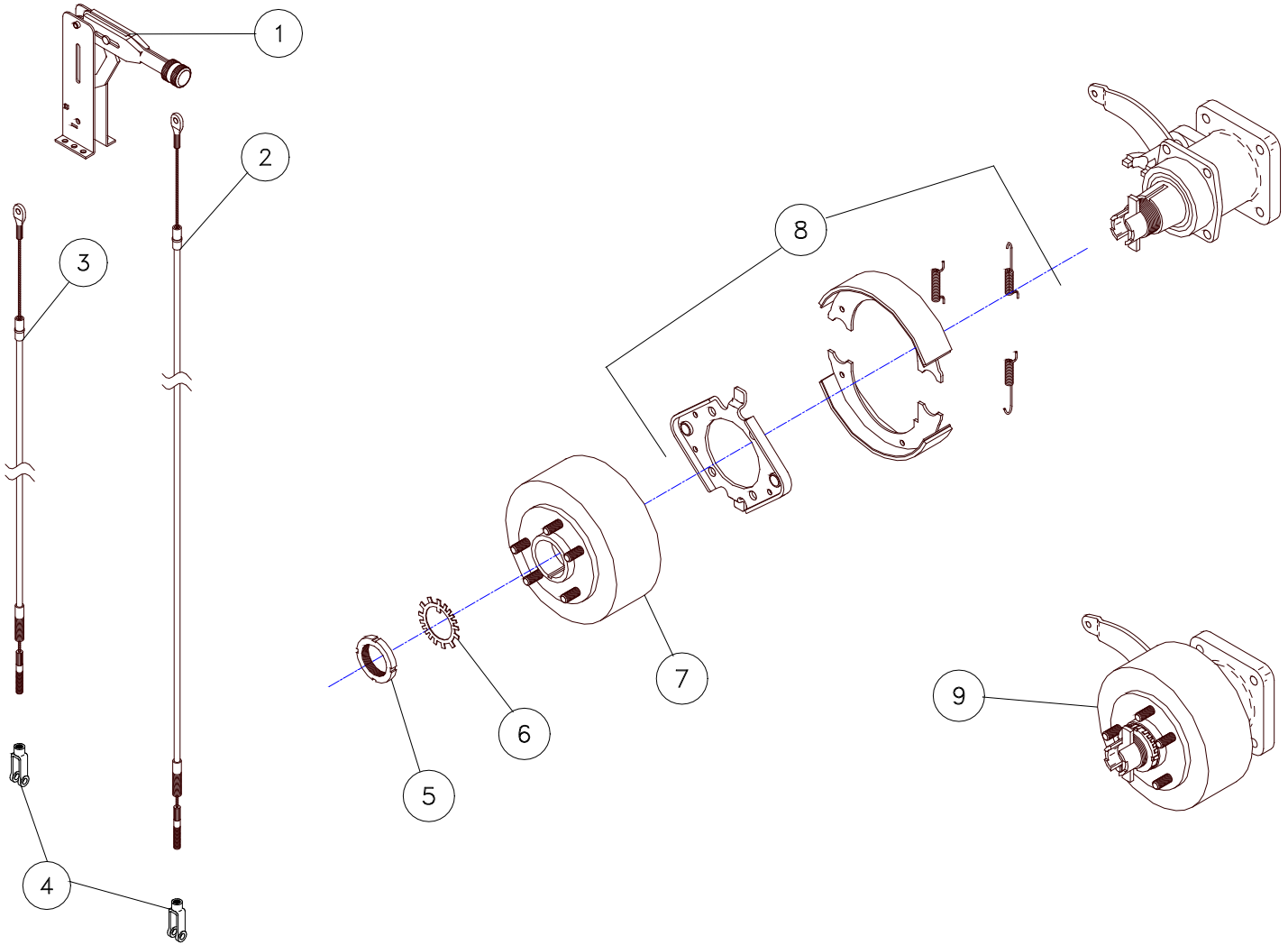

Ref #	Part #	Qty	Description
1	344179	1	Parking Brake Lever
2	344180	1	Parking Brake Cable 70"
3	344181	1	Parking Brake Cable 40"
4	B-27084A	2	Clevis 3/8" x 3" NF
5	344192	1	Spanner Nut
6	344193	1	Lock Washer
7	344194	1	Brake Drum
8	344189	1	Brake Assy.
9	344219	1	Wheel Assy w/Brake (complete)

DRIVE HUB COMPONENTS

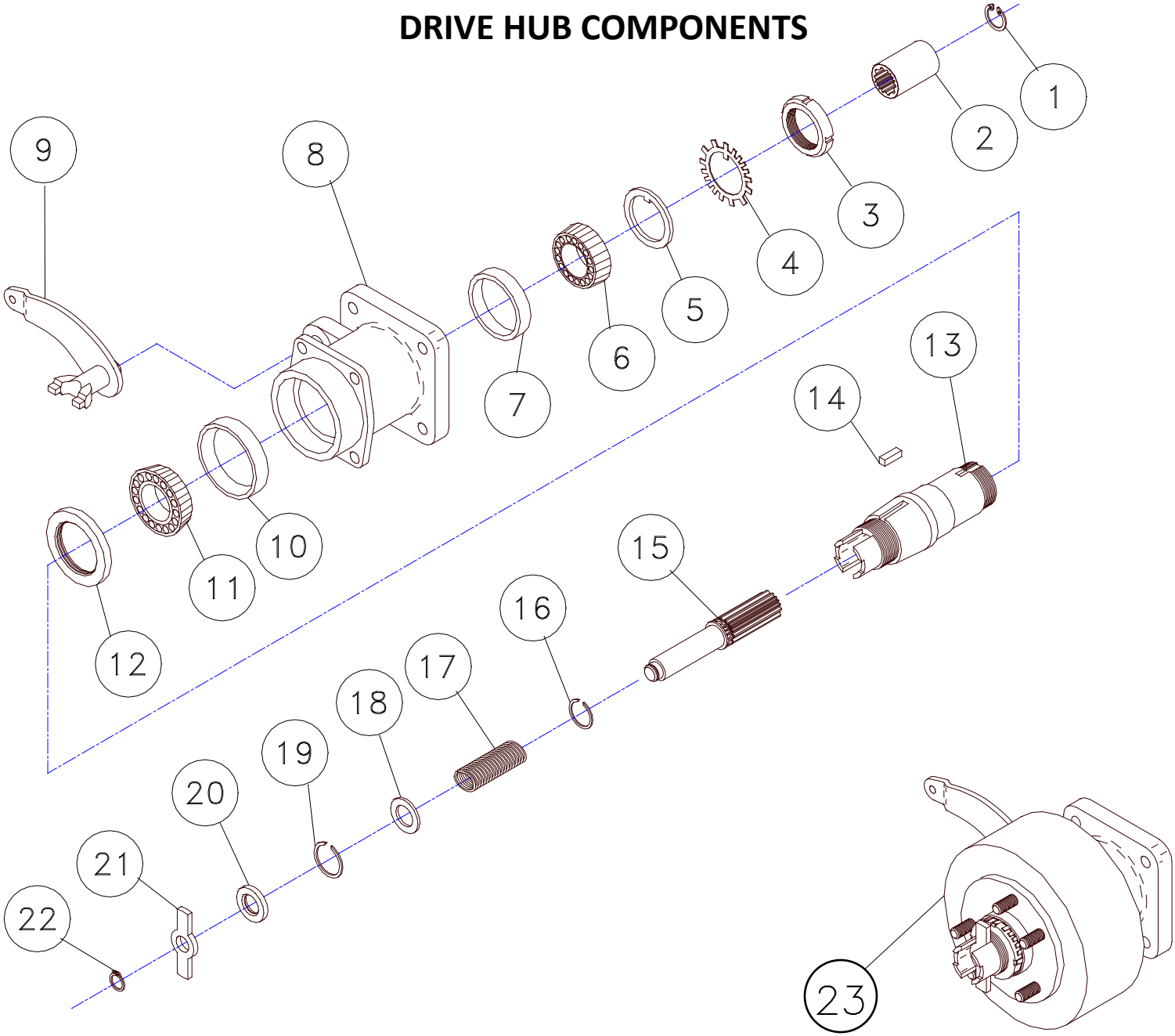

DRIVE HUB COMPONENTS

Ref #	Part #	Qty	Description
1	344199	1	Snap Ring I.D.
2	344200	1	Coupler Sleeve
3	344192	1	Spanner Nut
4	344193	1	Lock Washer
5	344201	1	Tongued Washer
6	344202	1	Bearing Cone, Inner
7	344203	1	Bearing Cup, Inner
8	344204	1	Drive Hub Housing
9	344205	1	Brake Lever
10	344206	1	Bearing Cup, outer
11	344207	1	Bearing Cone, outer
12	344208	1	Seal
13	344209	1	Spindle
14	344210	1	Key 5/16 x 1
15	344211	1	Shaft
16	344212	1	Snap Ring O.D.
17	344213	1	Spring
18	344214	1	Washer
19	344215	1	Snap Ring I.D.
20	344216	1	Seal
21	344217	1	Handle
22	344218	1	Snap Ring O.D.
23	344219	2	Drive Hub Assy.

BROCE BB-250 DRIVE HUB INSTALLATION NOTES

APPLY 1/8" SILICONE BEAD ALL THE WAY AROUND. WE USE DOW CORNING 700.

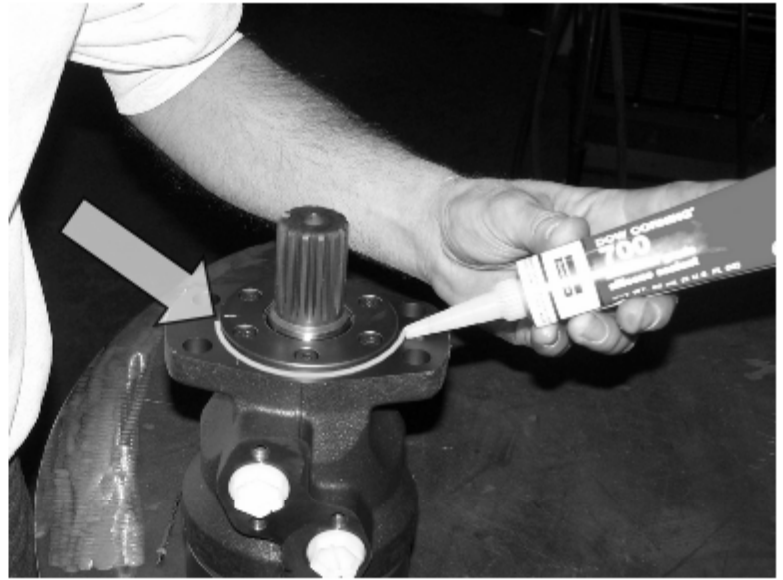

REMOVE BOTH SCREWS AND FILL WITH 30W OIL UNTIL IT RUNS OUT OF THE LOWER HOLE.

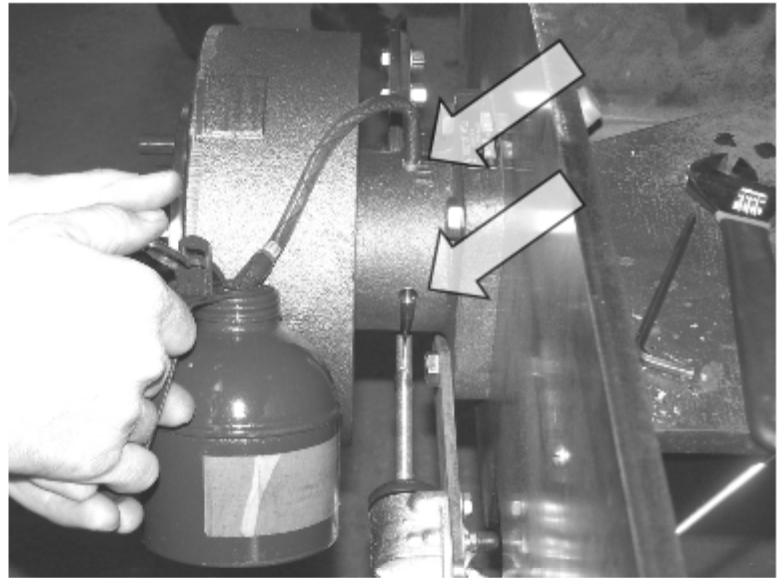

REPLACE LOWER SCREW AND PUMP MORE OIL (APPROXIMATELY 10 MORE PUMPS). REPLACE UPPER SCREW.

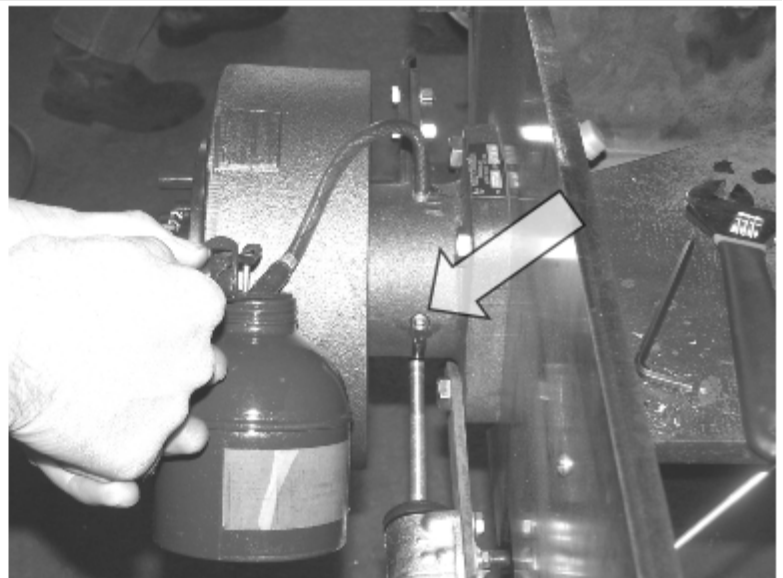

ACCELERATOR PEDAL & LINKAGE

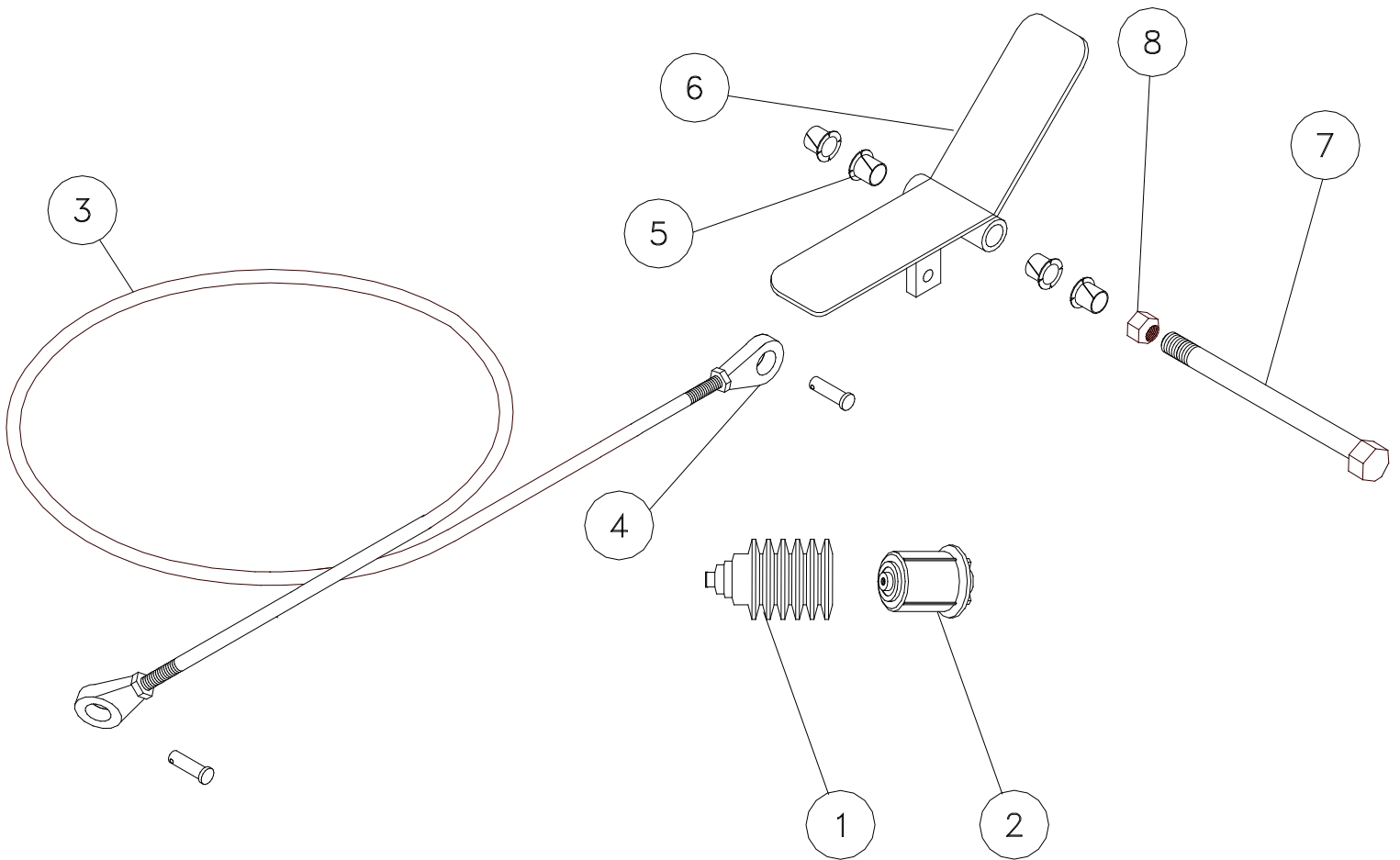

Ref #	Part #	Qty	Description
1	HC-228-B	1	Boot
2	HC-228-HB	1	Hydro-Back Centering Device
3	HC-228-E	1	Hydro-Back Cable
4	309453	2	Cable End
5	2461	4	Pivot Bushing
6	850146	1	Foot Pedal
7	400357	1	5/8 x 11 x 7" (Bolt Only)
8	400052	1	5/8 Nylon Nut

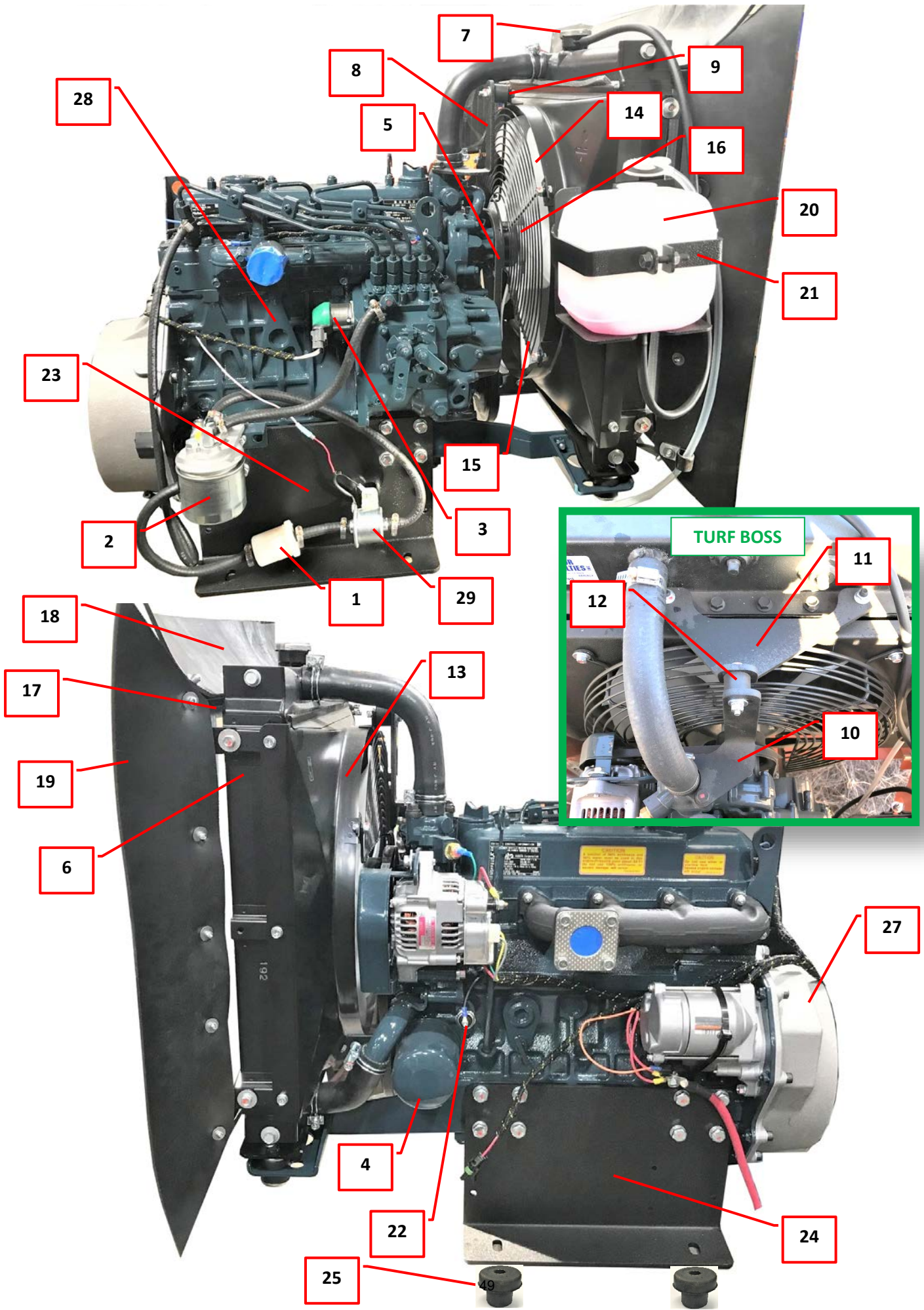

ENGINE-RELATED PARTS

Ref	Part #	Qty	Description
1	344237	1	Fuel Filter (Inline)
2	344244	1	Fuel Filter (Spin-On)
	15224-4301-0	1	Fuel Filter (Complete with Head)
3	17208-60010	1	Fuel Stop Solenoid
4	344229	1	Oil Filter Cartridge
5	344247	1	Fan Belt
6	344292	1	Radiator Complete (limited availability)
	202675	1	Radiator Complete (Turf Boss)
7	344246	1	Radiator Cap
	CALL	1	Radiator Cap (Turf Boss)
8	202604	1	Engine to Radiator Mount
9	304115	1	Engine to Radiator Rubber Isolator
10	202690	1	Engine to Radiator Mount (Turf Boss)
11	202688	1	Radiator to Engine Mount (Turf Boss)
12	304096	1	Engine to Radiator Rubber Isolator (Turf Boss)
13	344245	1	Fan Shroud
	202680	1	Fan Shroud (Turf Boss)
14	344227	1	Cooling Fan
	202677	1	Cooling Fan (Turf Boss)
15	344241	1	Fan Finger-Guard
	202679	1	Fan Finger-Guard (Turf Boss)
16	Kubota Part	1	Fan Spacer
	203805	1	Fan Spacer (Turf Boss)
17	202620	1	Air Duct Frame (Standard Radiator)
	202685	1	Air Duct Frame (Turf Boss Radiator)
18	202621	2	Air Duct Seal Top & Bottom (Standard Radiator)
	202686	2	Air Duct Seal Top & Bottom (Turf Boss Radiator)
19	202622	2	Air Duct Seal Left & Right (Standard Radiator)
	202687	2	Air Duct Seal Left & Right (Turf Boss Radiator)
20	344243	1	Coolant Recovery Bottle
21	202656	1	Radiator Overflow Tank Bracket
NS	344243A	1	Coolant Recovery Kit (Bottle & Bracket)
22	344235	1	Oil Pressure Switch
23	202607	1	R.H. Motor Mount
	202681	1	R.H. Motor Mount (Turf Boss)
24	202608	1	L.H. Motor Mount
	202682	1	L.H. Motor Mount (Turf Boss)
NS	850683	1	Radiator Underside Cross Member (Turf Boss)
25	344107	4	Rubber Engine Isolator
27	344251	1	Engine Drive Housing
NS	344252	1	Drive Plate
NS	344253	1	Drive Plate Hub
28	344166	1	Kubota Engine (complete)
29	344226	1	Fuel Pump (electric)

ENGINE-RELATED PARTS

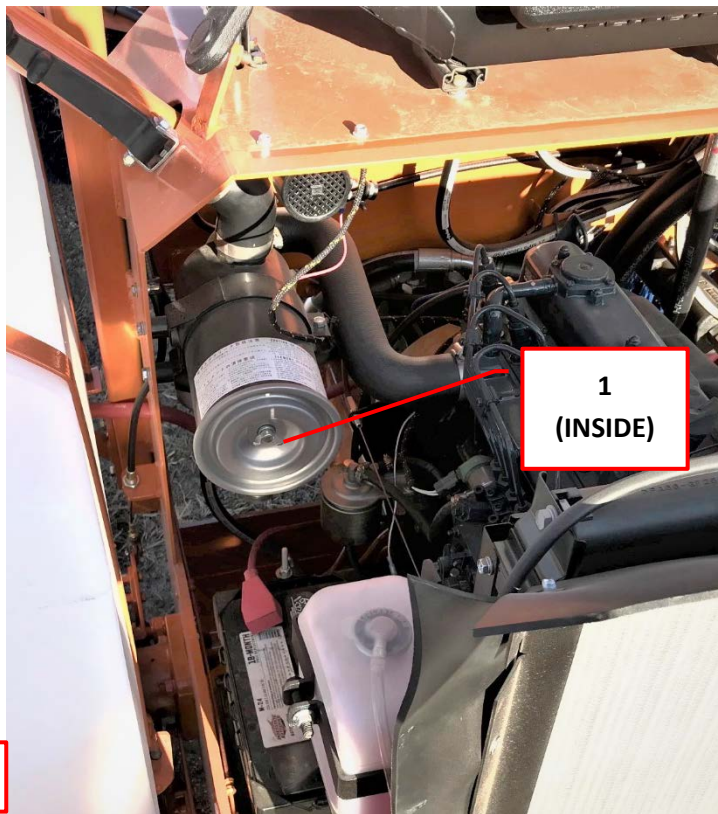
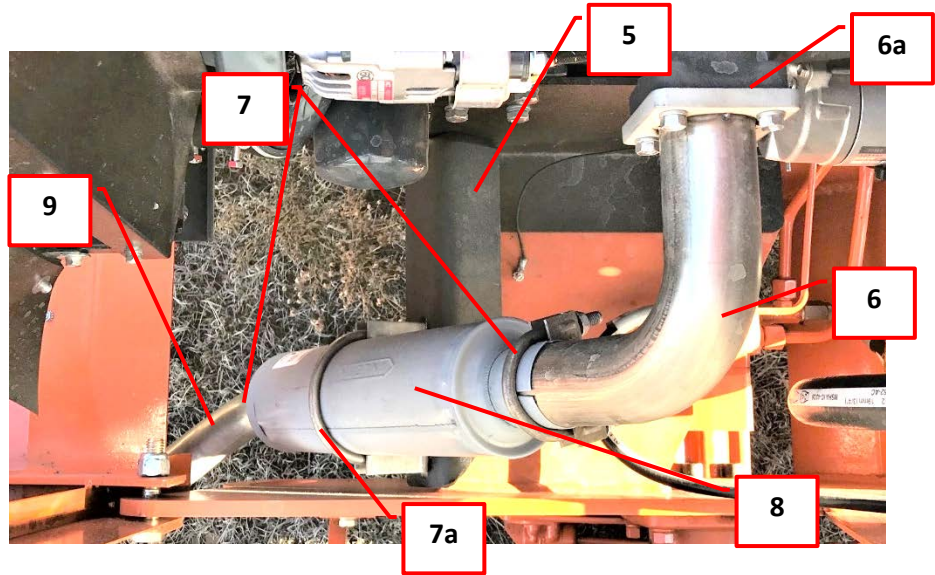
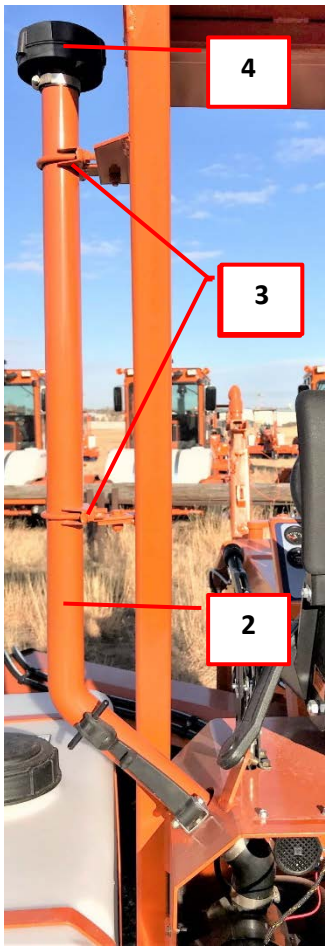

ENGINE-RELATED PARTS

Ref	Part #	Qty	Description
1	344249	1	Air Cleaner Filter Element
2	344093	1	Precleaner Inlet Pipe
3	850148	2	Precleaner Inlet Pipe Clamp
4	304064	1	Precleaner Complete
4.1	B9NN9A663A	1	Precleaner Bowl Only
5	202593	1	Tail Pipe Bracket
6	850127	1	Exhaust Manifold Pipe (Kubota)
6a	344260	1	Exhaust Manifold Gasket
7	344099	2	Muffler Pipe Clamps 2"
7a	302110	1	Muffler Clamp 3 ½"
8	310079	1	Muffler
9	344091	1	Exhaust Tail Pipe
10	HD-57	1	Battery Hold Down with J-Bolts

GAUGES, SWITCHES & LIGHTS

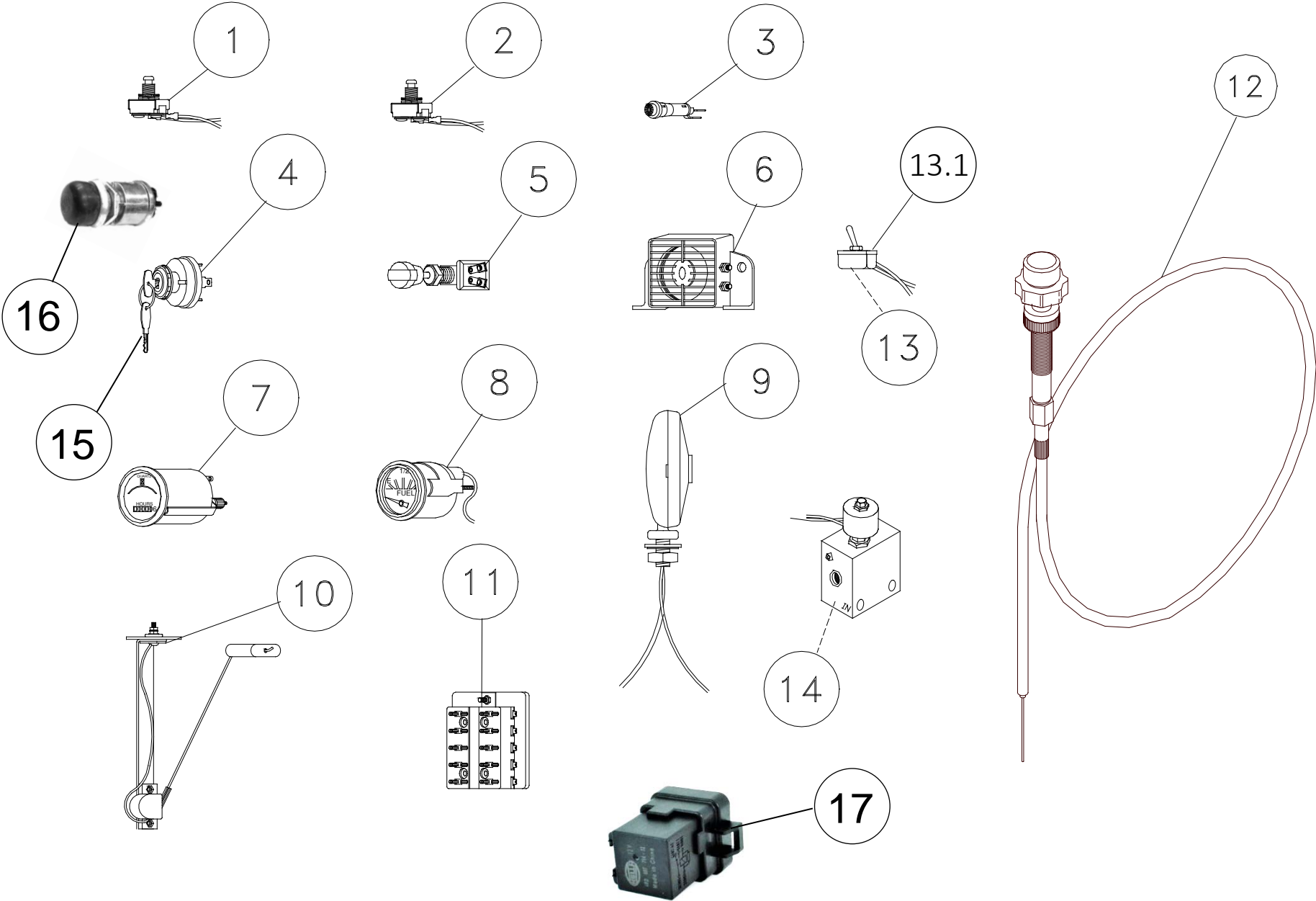

GAUGES, SWITCHES & LIGHTS

Ref #	Part #	Qty	Description
1	307098	1	Parking Brake Switch
2	344255	1	Reverse Alarm Switch
3	PBL-12	4	Warning Light
4	307044	1	Key Switch Kubota
5	23836	1	Push Pull Switch
6	RH-250	1	Reverse Alarm
7	I-222-HO	1	Hour Meter
8	I-223-R	1	Fuel Gauge
9	307031	2	Taillight
9.1	307043	2	Taillight (Turf Boss)
10	344175	1	Fuel Sender Gauge
11	46050-6	1	Fuse Block Standard, 6 Gauge
	46050-8	1	Fuse Block Optional, 8 Gauge
	46050-10	1	Fuse Block Optional, 10 Gauge
12	T-213-R	1	Throttle Cable
13	307071	1	Core Lock Switch
13.1	307454	1	Reversing Brush Dashboard Switch (Turf Boss)
14	305763	1	Core Lock Solenoid
15	307045	1	Key's (Pair)
16	307235	1	Starting Aid Switch on Dashboard
17	307913	1	Skirted Mini Relay 20/40A

WATER SPRAY SYSTEM

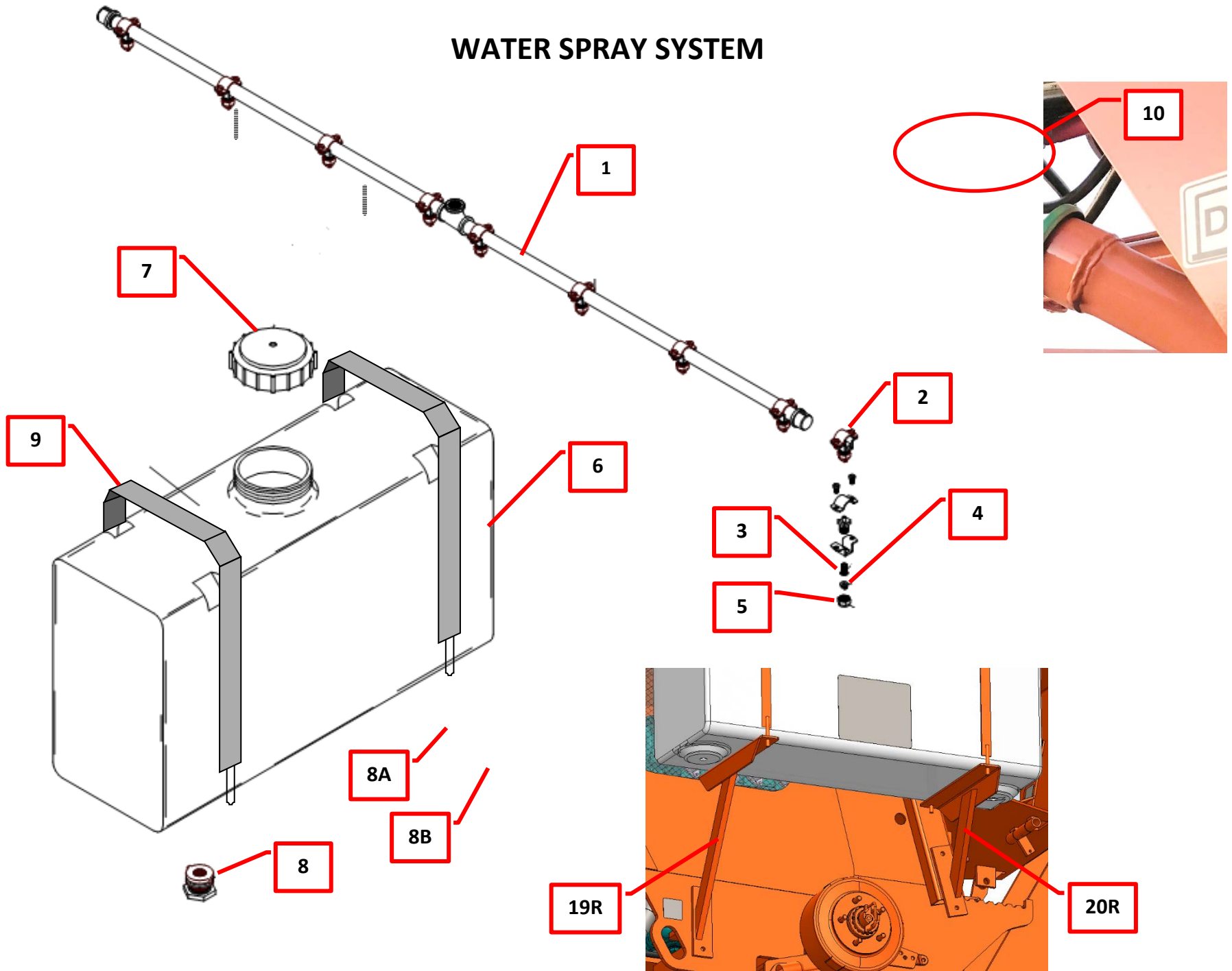

WATER SPRAY SYSTEM

Ref #	Part #	Qty	Description
1	WS-154	1	Spray Bar Complete
2	WS-155	8	Spray Nozzle Assy. Complete
3	WS-158	8	Nozzle Screen
4	TP 8002	8	Spray Tip
5	1458	8	Cap, Spray Tip
6	344178	2	Water Tank (complete) Poly
7	WS-145-D	2	Filler Cap 6" Plastic
8	306618	2	Tank Drain Plug
8A	WS-176-E	1	¾ NPT Female to 1¾
8B	345012	1	Fitting ¾ MNPT x ½ 90°
9	850160	4	Tank Hold-Down Strap
10	306950	1	Back Flow Check Valve (under Hydraulic tank)
10A	345009	2	Check Valve Fittings (one on each end of valve)
11	302402	1	Water Pump
12	WS-148	1	Inline Strainer (complete) Plastic
13	344254	1	Ball Valve 3/4 (plastic)
14	345010	1	Fitting 3/8 MNPT X 1/2 Barb
15	306112A	1	3/8 Close Nipple PVC
16	306429A	1	Bushing 3/4-3/8 PVC
17	306120	1	3/4 Close Nipple
18	306902	1	TEE 1/2 Hose Barb X 3/4 Pipe
19R	852522	1	Water Tank Mount Right-Rear
19L	852521	1	Water Tank Mount Left-Rear
20R	852524	1	Water Tank Mount Right-Front
20L	852523	1	Water Tank Mount Left-Front

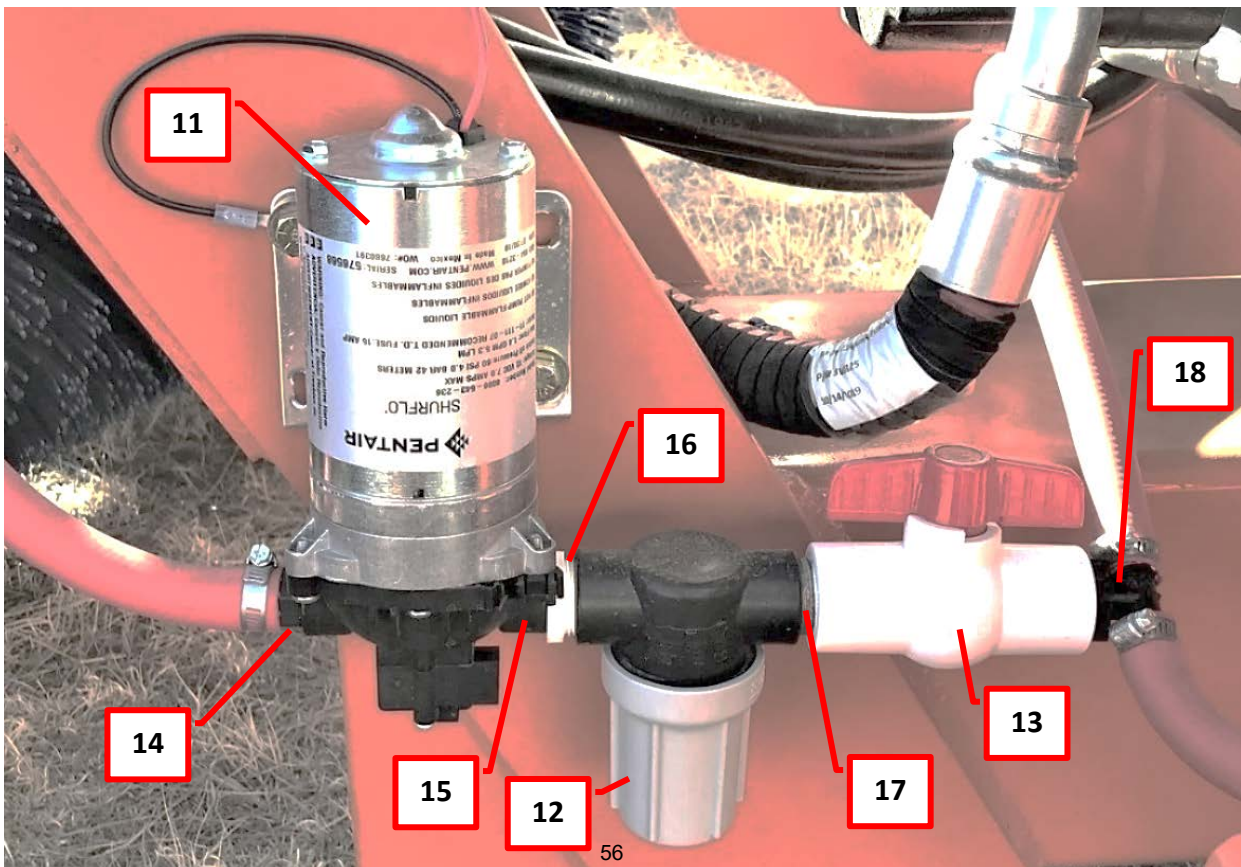

LIGHTS & OTHER OPTIONS

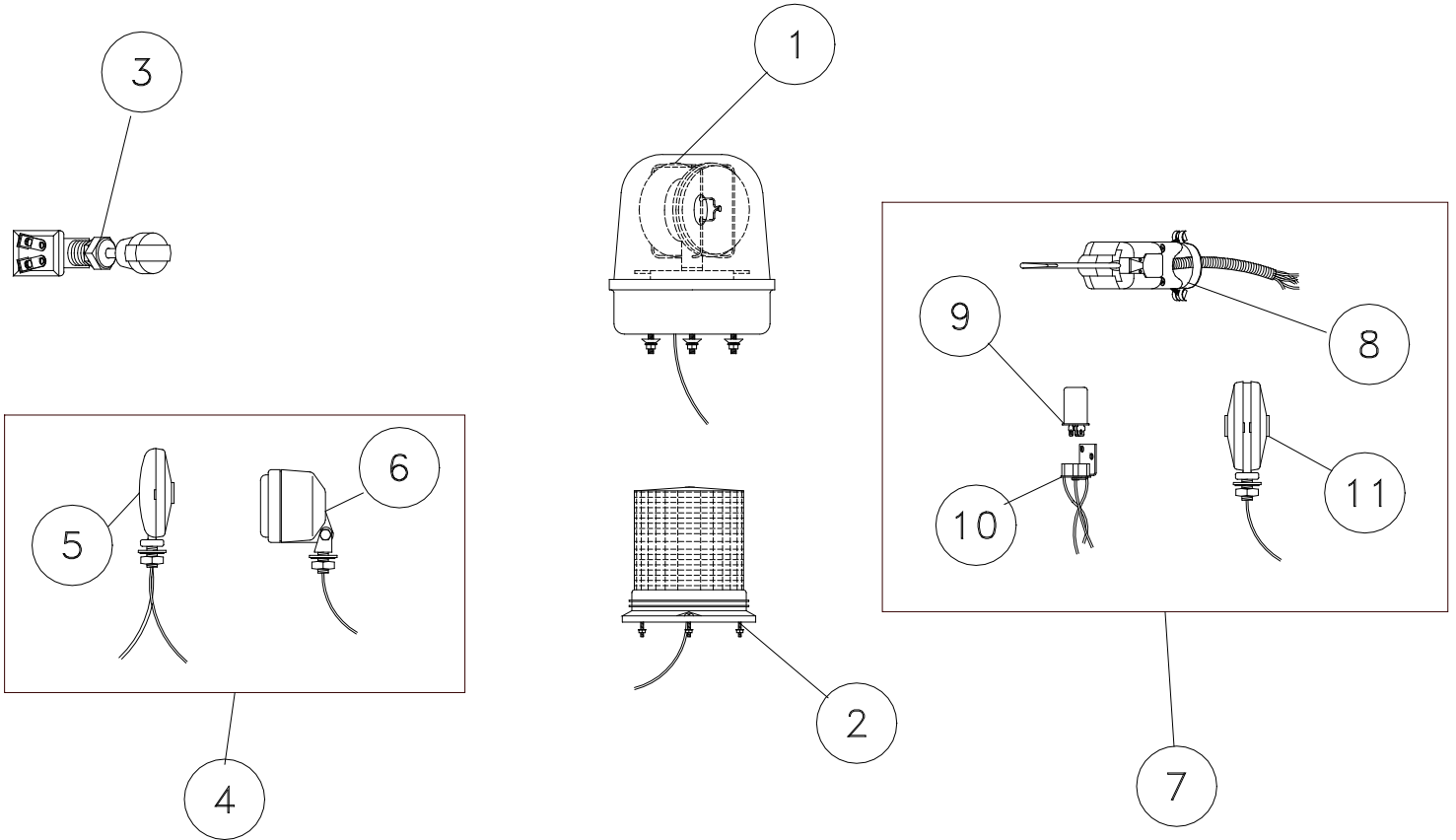

Ref #	Part #	Qty	Description
1	7-40004	1	Amber Beacon
2	3614A	1	Amber Strobe Light
3	23836	1	Push Pull Switch
4	LG-100-250	1	Light Group Kit
5	6-70001	2	Tail Light
6	9-50004-SBA	2	Utility Work Light (front or rear)
7	LG-100-TS	1	Light Group, Turn Signal Pkg.
8	16-35800	1	Turn Signal Switch
9	307024	1	Flasher
10	550FH	1	Flasher Socket
11	4-75001	1	Front Warning Light
12	344257	1	Engine Safety Shutdown Switch (Not Shown)

Broce Mfg. 3-Wheel Broom Wiring Diagram w/ Relay

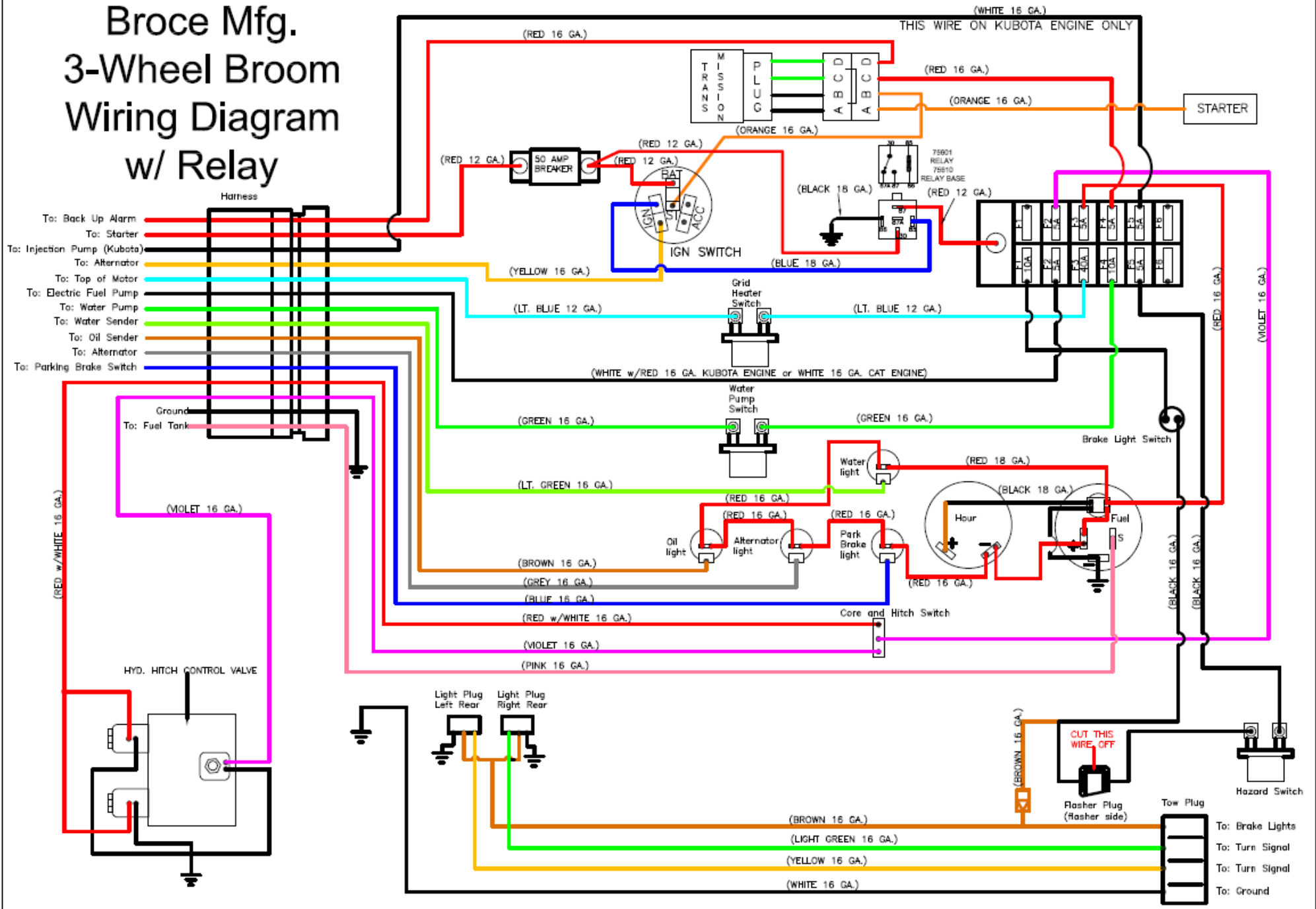

Broce Mfg. 3-Wheel Turf Broom Wiring Diagram

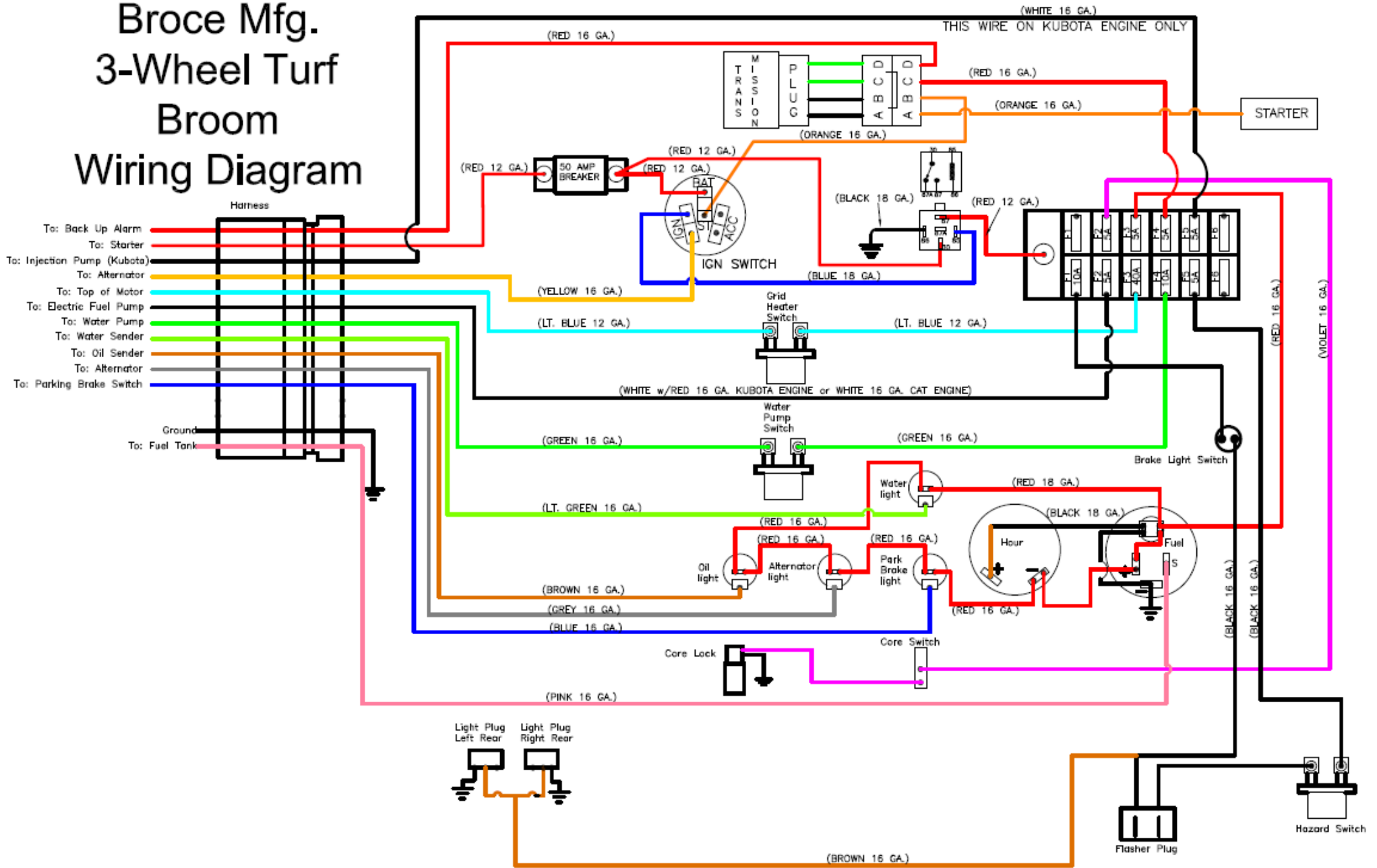

3 WHEEL MURPHY SWITCH WIRING

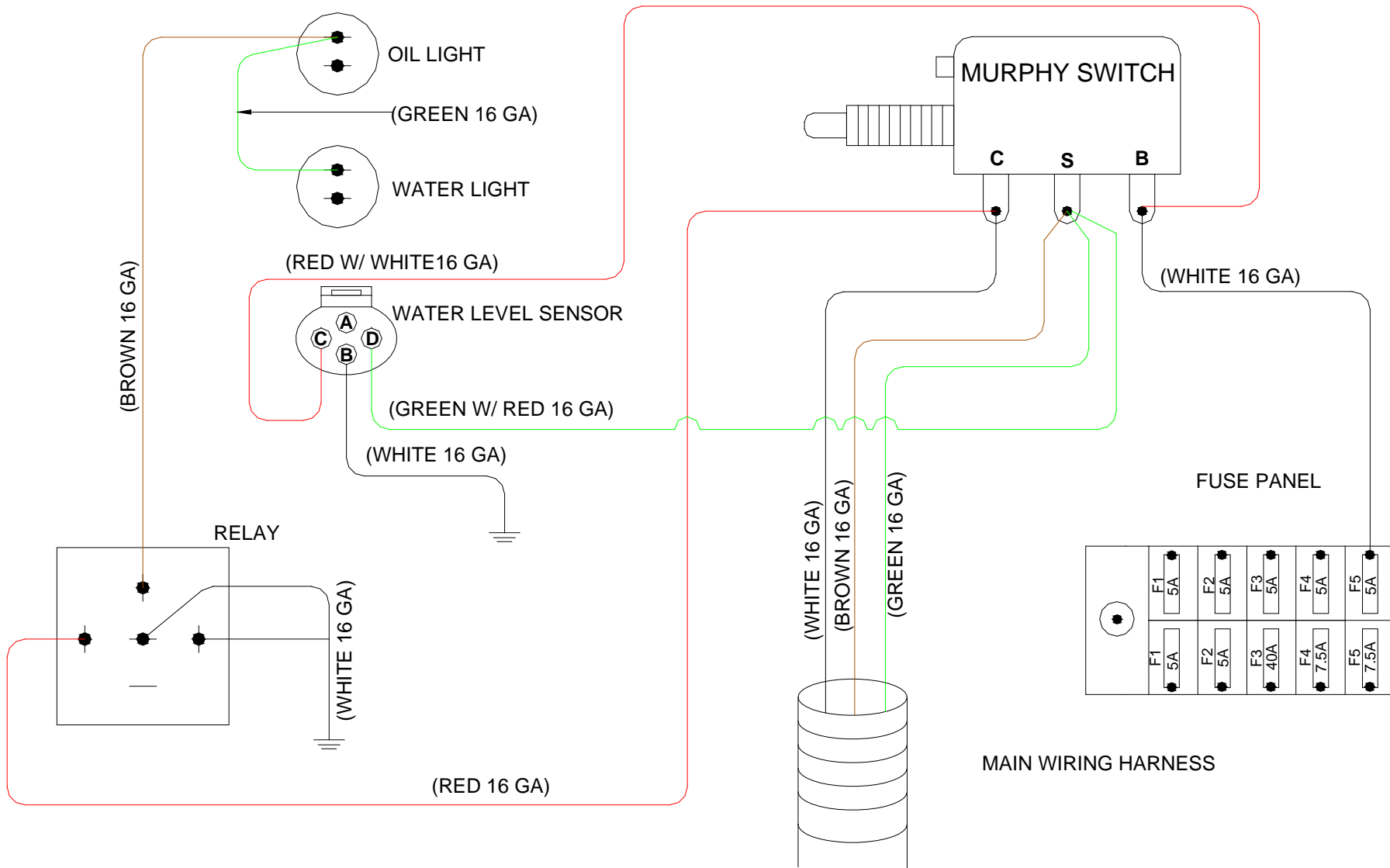

3 WHL VARIABLE SPEED W / SAUER CONTROLLER

PARTS LIST

CONTROLLER	307525
SPEED POT	307450
REVERSE SWITCH	307454

