

Operation & Maintenance

Broce Broom

BBA72P

Skid Steer Broom Attachment



Broce Manufacturing Co. Inc. - 1460 South 2nd Avenue - Dodge City, KS 67801
(877) 227-8811 - FAX (620) 227-3012 - parts@brocebroom.com
M-F 7:00 AM-6:00 PM CST

1-866-283-2759

March 2024

www.brocebroom.com

**Broce Manufacturing Company, Inc.
WARRANTY REGISTRATION**

Purchased From (Dealership)

Company: _____
Address: _____
City: _____ State: ____ ZIP: _____
Delivery Date to Dealer: ____ / ____ / ____ Unit Hours: _____
Model Number: _____ Serial Number: _____

Purchaser

Company: _____
Address: _____
City: _____ State: ____ ZIP: _____
Delivery Date to Dealer: ____ / ____ / ____ Unit Hours: _____

Purchaser - Type of Business			
Construction/Highway	Rental	Asphalt Contractor	
Equipment Dealer	Municipality	Other	

1. *The Purchaser has been instructed and/or has read the manual and understands proper preventive maintenance, operation and safety precautions.*
2. *The Warranty and Limitations of Liability are found in the Warranty pages enclosed in the Parts and Operators Manuals.*
3. *Broce Manufacturing Co. Inc. reserves the right to make design changes or modifications to Broce products at any time without incurring any obligation to make similar changes or modifications to previously sold units.*
4. *If this Document is not signed and returned to Broce Manufacturing Co. Inc., the warranty begins at the date of delivery to the Dealership.*

I hereby acknowledge acceptance of above and conditions in the Warranty Policy

Purchaser/Owner: _____

Dealer Representative: _____

Broce Manufacturing Co. Inc.
1460 South 2nd Avenue
Dodge City, KS 67801
(877) 227-8811

BROCE MANUFACTURING COMPANY
BROCE BROOM LIMITED TWELVE-MONTH WARRANTY

For a period of twelve (12) months or 1,000 hours whichever comes first, from the date of delivery of product to the original user, Broce Manufacturing of Dodge City, Kansas warrants each product to be free from manufacturing defects, subject to the limitations contained in this policy. This limited warranty covers parts and labor.

No alterations may be made to attachment without the expressed written consent of Broce Manufacturing company, as this could cause serious injury or death and will also void the warranty.

This warranty does not apply to defect caused, in whole or in part, by unreasonable use while in the possession of the user, including, but not limited to, failure to properly set up product, failure to provide reasonable and necessary maintenance, normal wear, routine tune ups or adjustments, improper handling, accidents, operation at speed or load conditions contrary to published specifications, improper or insufficient lubrication, or improper storage. This warranty is not a guarantee that the performance of each product will meet the expectations of the purchaser.

Broce Manufacturing shall not be liable for consequential damage of any kind, including, but not limited to: consequential labor costs or transportation charges in connection with the replacement or repair of defective parts, lost time or expense which may have accrued because of said defects. In no event shall Broce Manufacturing's total liability hereunder exceed the product purchase price.

Many components used by Broce Manufacturing are subject to the warranties of their respective manufacturers. These warranties will be considered void if the product is modified or repaired in any way not expressly authorized, or if closed components are disassembled prior to return. Closed components include, but are not limited to gearboxes, hydraulic pumps, motors, cylinders and actuators.

Our obligation under the warranty is expressly limited, at our option, to the replacement or repair at Broce Manufacturing of Dodge City, KS or at a service facility designated by us. We are not responsible for unauthorized repairs or replacements. Any implied or statutory warranties, including any warranty of merchantability or fitness for a particular purpose, are expressly limited to duration of this written warranty. We make no other express warranty. This warranty cannot be extended, broadened, or changed except in writing by an authorized officer of Broce Manufacturing.

Broce Manufacturing Co. Inc.
1460 South 2nd Avenue
Dodge City, KS 67801
(877) 227-8811

TABLE OF CONTENTS

<u>Safety Precautions</u>	<u>8-9</u>
<u>Attachment Specs</u>	<u>10</u>
<u>Serial Number Location</u>	<u>11</u>
<u>Attachment Operation.....</u>	<u>12</u>
<u>Adjusting Retention Chains</u>	<u>13-15</u>

Maintenance

<u>Lubrication</u>	<u>16</u>
<u>Adjusting Core Height</u>	<u>17</u>
<u>Broom Wafer Replacement.....</u>	<u>18</u>
<u>Motor Replacement.....</u>	<u>19</u>
<u>Idler Bearing Replacement</u>	<u>20</u>
<u>Cutting Edge Replacement</u>	<u>21</u>
<u>Water System.....</u>	<u>22</u>
<u>Troubleshooting</u>	<u>23</u>

Parts

<u>Full Assembly</u>	<u>25</u>
<u>Cover Assembly</u>	<u>26</u>
<u>Lever Arm Assembly- Left Hand</u>	<u>27</u>
<u>Lever Arm Assembly- Right Hand</u>	<u>28</u>
<u>Broom Core Assembly</u>	<u>29</u>
<u>Water System.....</u>	<u>30</u>
<u>Electrical</u>	<u>31</u>
<u>Hydraulic Diagram</u>	<u>32</u>
<u>Valve Breakdown</u>	<u>33</u>
<u>Decals</u>	<u>34-35</u>

<u>Service Parts to Stock</u>	<u>36</u>
<u>Notes</u>	<u>37</u>



WARNING: Cancer
and Reproductive Harm
www.P65Warnings.ca.gov



DANGER



MISUSE, OPERATION OR MAINTENANCE BY AN UNAUTHORIZED PERSON COULD LEAD TO SERIOUS INJURY OR DEATH

Operation of this equipment shall be limited to a competent and experienced person. In addition, anyone who will operate or work around this equipment must use good common sense. In order to be qualified, he or she must also know and meet all other requirements, such as:

1. Some regulation specify that no one under the age of 16 may operate power machinery. It is your responsibility to know what these regulations are in your area or situation.
2. Current OSHA regulations state in part: "At the time of initial assignment and at least annually thereafter, the employer shall instruct **EVERY** employee in the safe operation of servicing of all equipment with which the employee is or will be involved."
3. Unqualified person must **STAY OUT** of the work area.
4. A person who has not read and understood all operating and safety instructions is not qualified to operate the machinery.
5. While machine is in operation, there should be no bystanders within 15 to 20 feet of the machine.
6. Absolutely **NO RIDERS** on the attachment.

FAILURE TO READ THIS MANUAL AND IT'S SAFETY INSTRUCTIONS IS A MISUSE OF THE EQUIPMENT AND WILL VOID FACTORY WARRANTY.



WARNING: Cancer
and Reproductive Harm
www.P65Warnings.ca.gov

SAFETY PRECAUTIONS

Entering and Exiting the Operator's Position

Only Enter or Exit the skid steer/loader where proper handholds and steps are available. Inspect the handholds and step for any damage prior to use and perform repairs when necessary. Keep all handholds and steps clean to avoid serious injury.

Maintain 3 contact points with the skid steer/loader and attachment when entering and exiting the operator's position. Face the skid steer/loader when entering and exiting the operator's position. NEVER enter, exit, climb, or jump on a moving or operating attachment.

Maintenance Shutdown Procedure

ALWAYS perform the "Maintenance Shutdown Procedure" **BEFORE** adjusting, lubricating, cleaning, or servicing the attachment. See below for the "Maintenance Shutdown Procedure".

1. Lower the boom arm and rotate the attachment until the bucket contacts the ground and sits flat.



2. Apply the parking brake, turn off the skid steer/loader engine, and remove the key from the ignition. **DO NOT** reinsert the key into the ignition until any required maintenance or adjustment is complete.
3. Relieve the pressure in the hydraulic lines by actuating the skid steer/loaders boom controls. NOTE: reference the skid steer/loader's manual for exact pressure relieving methods.
4. Disconnect the attachment's hydraulic lines from the skid steer/loader.



WARNING: Cancer
and Reproductive Harm
www.P65Warnings.ca.gov

ATTACHMENT SPECIFICATIONS

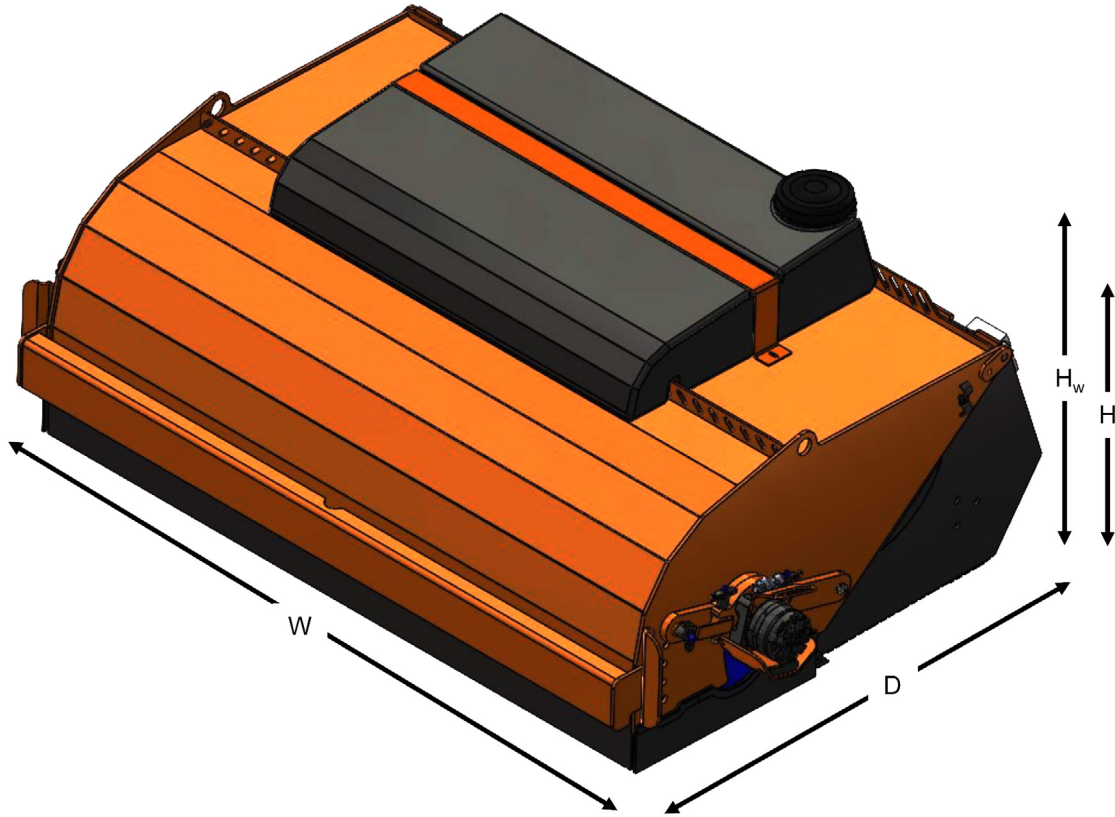

BBA60P	
Brush Width	72"
Overall Width (W)	84.74"
Overall Depth (D)	60.57"
Standard Package Overall Height (H)	25.76"
Standard Package Weight (lb _s)	2050 lbs
Wafer Diameter	24"
Input Flow Range	12-30 GPM
Operating Pressure	3000 PSI
Water System	Optional
Weight with Full Water System (lb _w)	2450 lbs
Overall Height with Water System (H _w)	33.67"

 **WARNING:** Cancer and Reproductive Harm
www.P65Warnings.ca.gov

SERIAL NUMBER LOCATION

The model/serial number plate is located on the right-hand side of the step. If the model/serial plate cannot be read, the serial number is stamped on the back side of the bucket cross-member directly above the step. See the image below for more details.

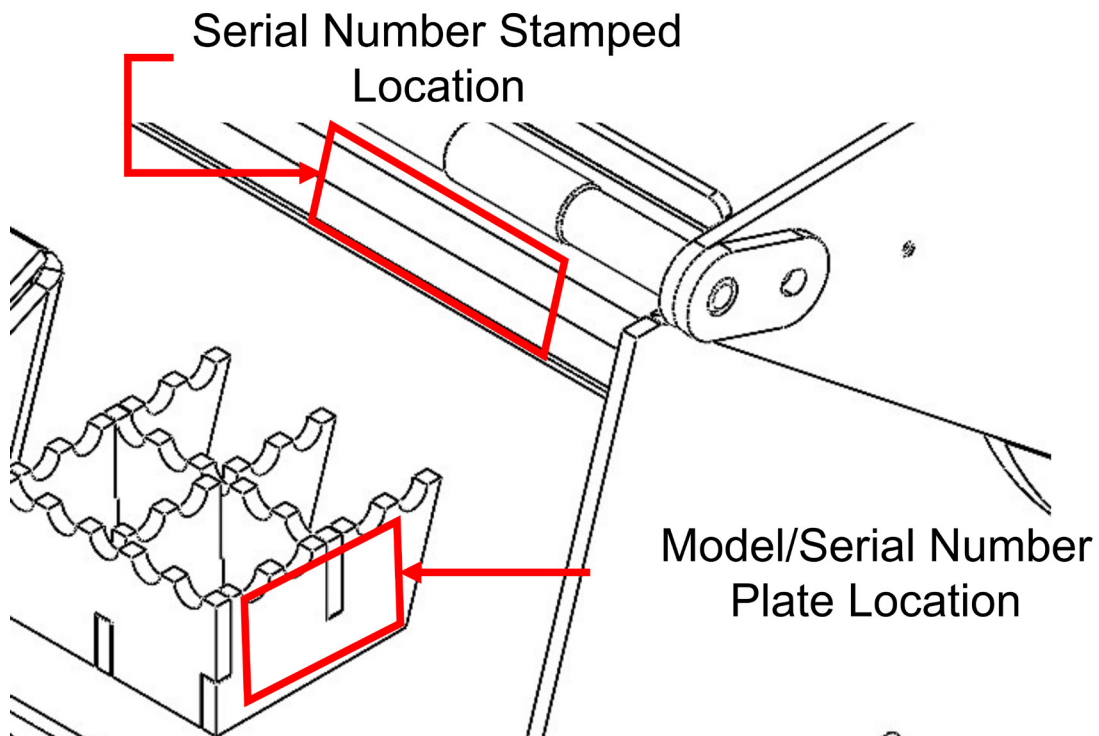

WARNING: Cancer
and Reproductive Harm
www.P65Warnings.ca.gov

ATTACHMENT OPERATION

Setup and Pre-use checks

Before operating the attachment, perform the following “Pre-use Checks.”

1. Ensure all safety decals are legible and free of excessive damage.
2. Check all hydraulic hoses and adapters for leaks and ensure they are tight.
3. Inspect all hydraulic hoses for damage or kinks. Hoses should be free to move during operation and dumping.
4. If the unit has an optional water system, check the wiring and water hose for potential catching or kinking.



Coupling the Attachment to a Skid Steer

1. Start the skid steer/loader engine, retract the attachment pins, and roll the coupler forward.
2. Center the skid steer/loader to the attachment and hook the coupler to the upper attachment strip. Roll the coupler backward and lift the attachment off the ground.
3. Actuate the attachment pins, ensuring the pins are completely engaged. Reference the skid steer/loader operations manual for more detail.

Connecting the Hydraulic Couplers

1. Perform the first three steps of the “Maintenance Shutdown Procedure” found on page 9 before connecting the hydraulic hoses to the skid steer/loader.
2. Inspect the hydraulic couplers for debris or damage prior to connecting the hoses. Clean or replace the couplers if necessary.
3. Press the couplers onto their corresponding couplers on the skid steer/loader. There should be an audible click when properly engaged.
4. Pull on the couplers to ensure they are properly connected.
5. Slowly roll the bucket back to check for interference between the hydraulic couplers and the bucket.
6. If the coupler interferes with the attachment, replace the coupler and straight adapter with the included stubby coupler and 90-degree adapter.



WARNING: Cancer
and Reproductive Harm
www.P65Warnings.ca.gov

ADJUSTING THE COVER RETENTION CHAINS

This attachment was designed to be used with “Cover Retention Chains.” The purpose of the chains is to allow the bucket to be dumped independently of the cover. Reference the following for proper chain adjustment.

⚠ WARNING ⚠

Failure to properly adjust the retention chains can result in damage to the attachment. This adjustment must be performed if the skid steer/loader has changed between adjustments.

1. **ALWAYS** begin by performing the “Maintenance Shutdown Procedure” found on page 9.
2. **ALWAYS** start the adjustment process with one (1) safety hook installed on each chain, as shown below.

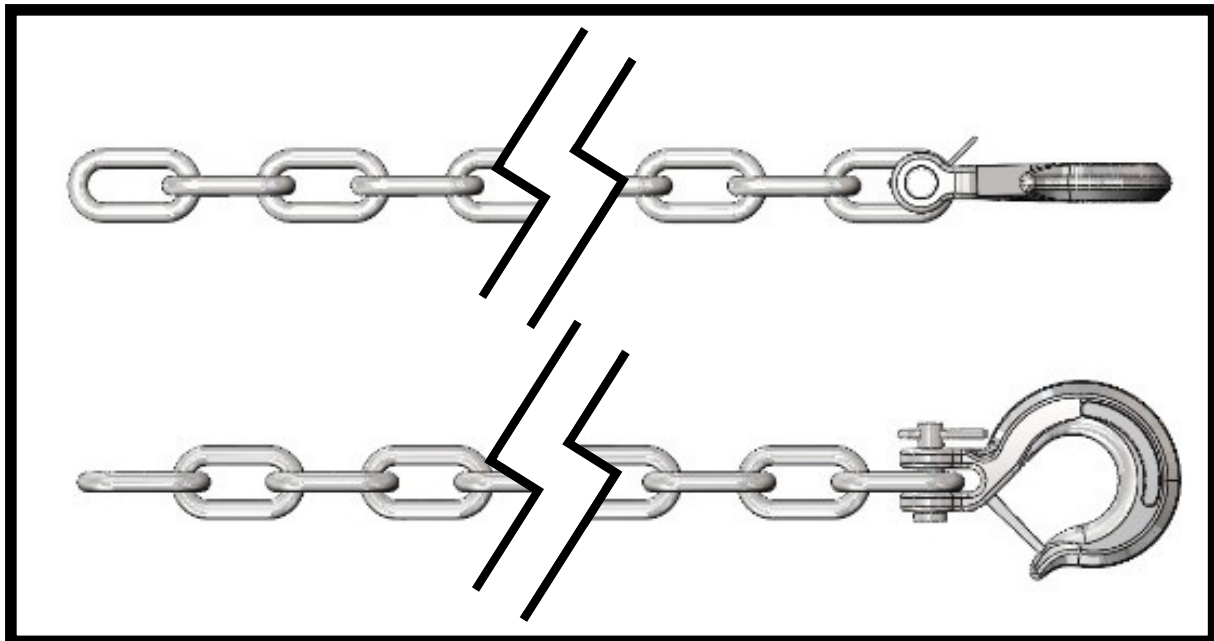

3. Hook each chain to a secure location on the skid steer/loader’s boom arm.

⚠ CAUTION ⚠

ALWAYS perform step 3 independently for each chain assembly. The chain assembly lengths may differ depending on the chain mounting location on the skid steer/loader.



WARNING: Cancer and Reproductive Harm
www.P65Warnings.ca.gov

ADJUSTING THE COVER RETENTION CHAINS

4. Pull the chain tight toward the attachment chain eyelet. Mark the link that reaches the center of the eyelet, move one (1) link down the chain from the marked link, and install the safety hook. Attach the chain to the attachment chain eyelet. See the image below for more details.

⚠ WARNING ⚠

Failure to securely fasten the chain to either the loader or attachment could result in the chain slipping and could cause damage to the unit or serious injury.

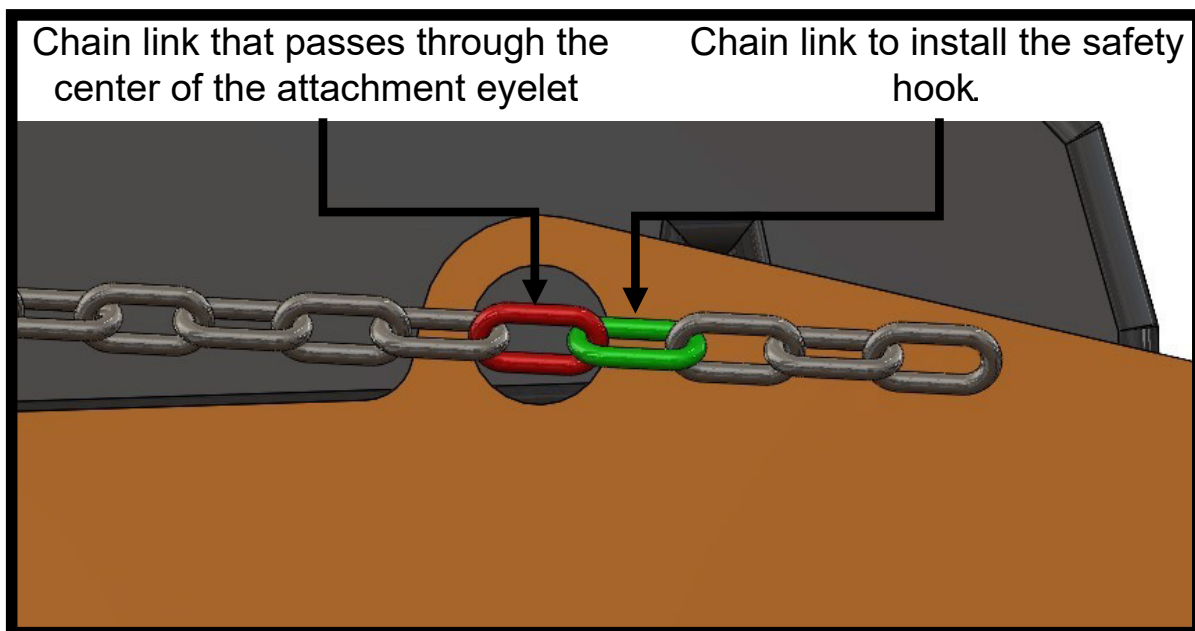

⚠ WARNING ⚠

Failure to securely fasten the chain to either the loader or attachment could result in the chain slipping and could cause damage to the unit or serious injury.



WARNING: Cancer
and Reproductive Harm
www.P65Warnings.ca.gov

ADJUSTING THE COVER RETENTION CHAINS

5. Start the skid steer/loader's engine, raise the boom arm, and slowly roll the bucket forward into the dumping position.

⚠ CAUTION ⚠

While rolling the bucket into the dumping position, ensure the cover stop does not collide with the bucket stop. Longer chains may be required if the cover stop contacts the bucket stop before reaching the desired dumping position. **NEVER** use chains that are too short. Failure to use the correct chain length could result in damage to the attachment. See the image below for more detail.

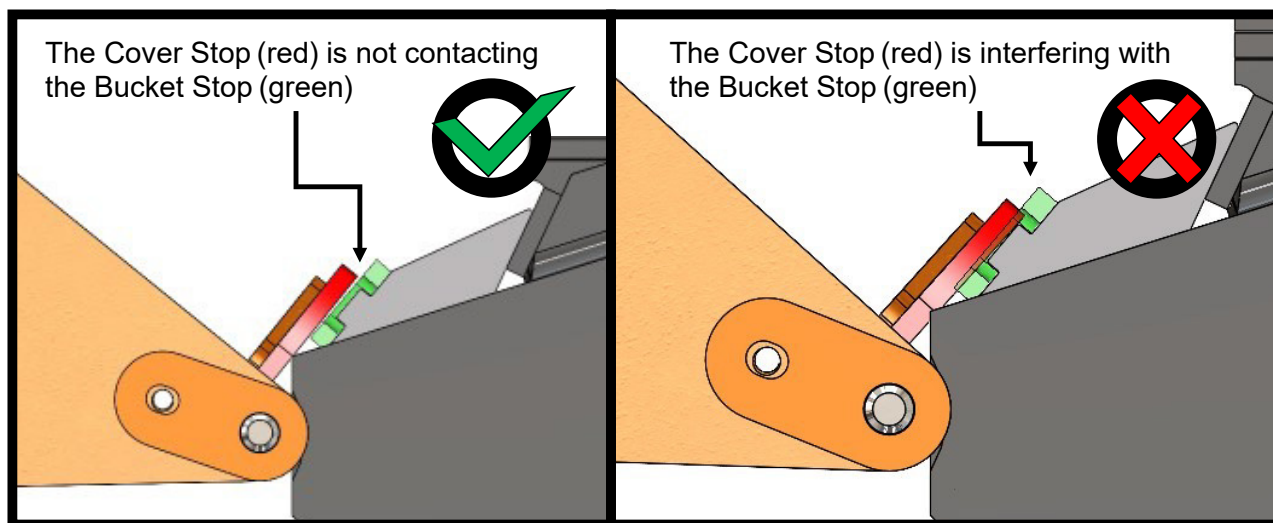

⚠ CAUTION ⚠

If the mounting location on the skid steer/loader results in a low chain angle, relative to the cover, the chain could wrap around the bucket during dumping potentially damaging the attachment. In this case, shorten the chain until it no longer contacts the bucket while dumping.

⚠ CAUTION ⚠

Shortening the chains in excess can result in damage to the cover during the dumping operation. Take extreme care during the chain adjustment process to properly set the chain length.

6. If the chains need to be adjusted, perform the "Maintenance Shutdown Procedure" found on page 9. Unhook the chain from the skid steer/loader, remove the hook pin, and relocate the hook by one chain link until the desired chain length is acquired.



WARNING: Cancer and Reproductive Harm
www.P65Warnings.ca.gov

MAINTENANCE (LUBRICATION)

The attachment has one grease zerk shown in the image below.

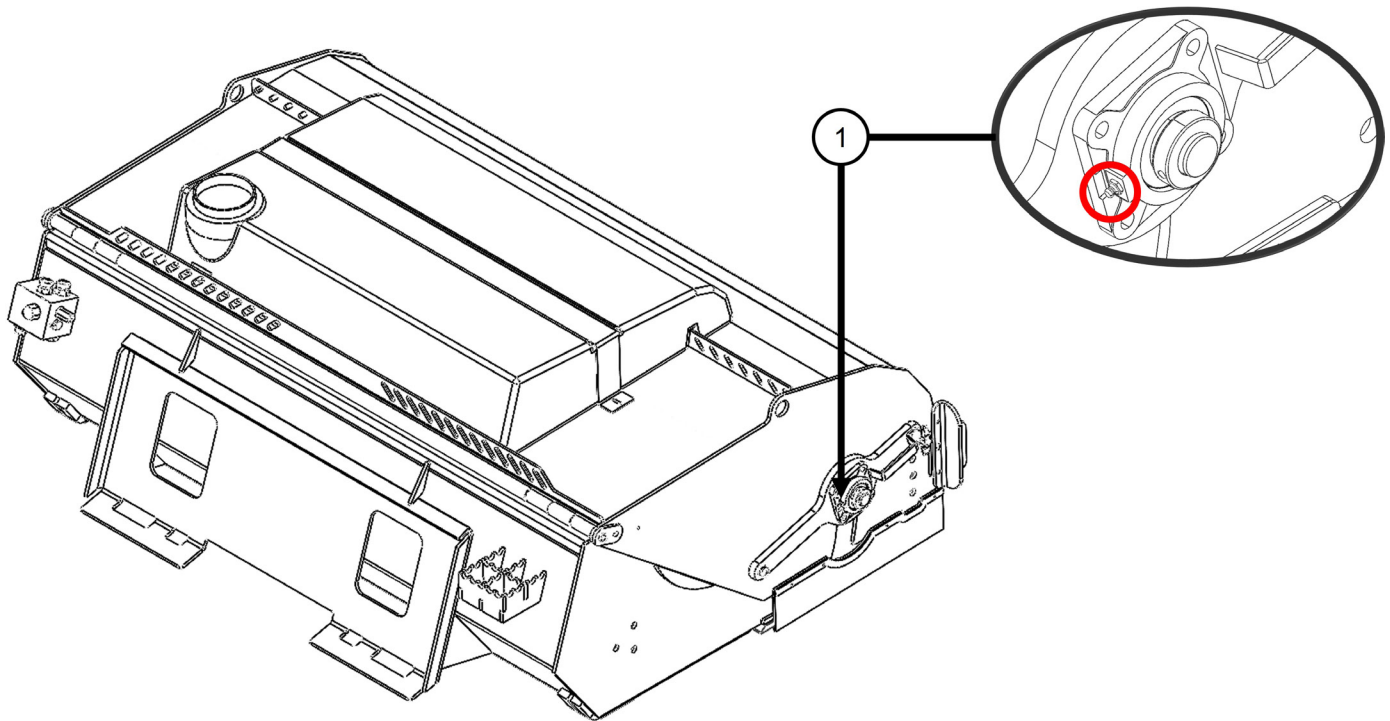

This is a sealed bearing and may require no lubrication throughout its service life. However, no more than two strokes of grease at 200-hour intervals are recommended if lubrication is deemed necessary. Seals are often destroyed by over-greasing sealed bearings. Perform the “Maintenance Shutdown Procedure” found on page 9 before greasing.

NOTE: The average grease gun outputs 0.025 - 0.035 ounces per stroke.



WARNING: Cancer
and Reproductive Harm
www.P65Warnings.ca.gov

MAINTENANCE

(ADJUSTING CORE HEIGHT)

Checking and Adjusting the Core Height

The five adjustment holes on the cover assembly's side plate control the core height.

The contact patch with the ground should be around 6.5 inches with a new wafer kit.

As the wafers wear, the contact patch will decrease. Once the contact patch decreases to a point where the attachment is unable to perform adequately, the core height must be adjusted.

To adjust the core height:

1. Depress the core adjustment pins' detent button and pull the pins out of the lever arms.
2. Lower the lever arms to the next available core adjustment hole on the cover side plate and pin the lever arms into place.

⚠ WARNING ⚠

Ensure the core adjustment pin detent button is fully extended and locked after pinning the lever arm into position. Failure to lock the corepins can result in damage to the attachment and possible injury.

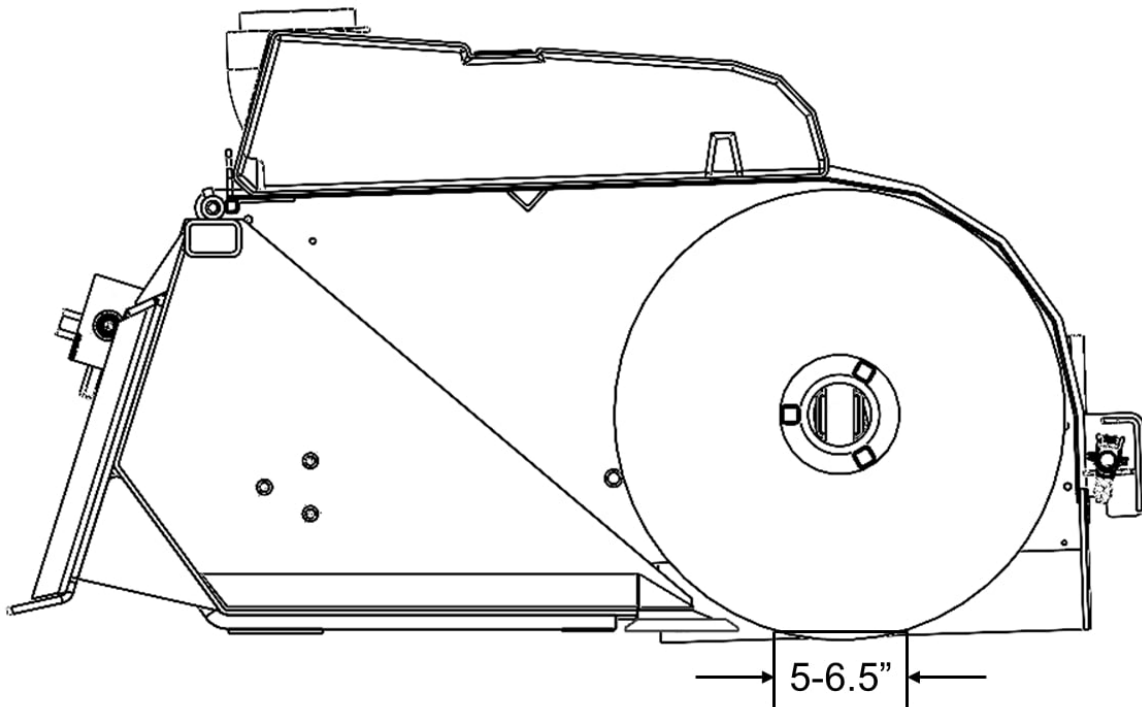

WARNING: Cancer
and Reproductive Harm
www.P65Warnings.ca.gov

MAINTENANCE

(BROOM WAFER REPLACEMENT)

Wafer Maintenance

The Broce Broom Attachment line uses a 6 3/8" x 24" convoluted wafer. See the table below for wafer quantities for 72 inch core.

Core Length (in)	Number of Wafers Required
72	40



IMPORTANT



Replacement wafer kits can be ordered from Broce Manufacturing at www.brocebroomparts.com or call 1-580-227-3711.

Removing the Broom Core

1. Lower the boom arm and rotate the attachment until the bucket contacts the ground and sits flat.
2. Perform the "Maintenance Shutdown Procedure" found on page 9.
3. Unbolt the side rubber skirts from the cover and set them aside.
4. Use an hex wrench to loosen the set screw on the idler-bearing lock ring.
5. Use a punch and hammer to turn the idler-bearing lock ring counterclockwise until the ring can be removed.
6. Depress the motor mounting pin plungers and pull both pins upwards to unlock the motor from the core lever arm.
7. Use the integrated handles on the motor to pull the motor out of the core.
8. Depress the core adjustment pin plunger on the idler-bearing side and remove the pin from the core adjustment arm.
9. Use a hoist or other adequate lifting device to lift the cover off the bucket's cover stops, allowing the idler-side arm to rotate below the cover.
10. Slide out the core from the motor side.



IMPORTANT



See page 29 for specific wafer kit ordering information.

Replacing the Brush Wafers

1. Rotate the broom core onto its motor side end.
2. Remove the 3 bolts holding on the idler assembly and remove the idler.
3. Remove each wafer by sliding them off the core.
4. Before installing new wafers, ensure the broom core is free of damage.
5. Install the wafers one at a time, clocking each 120° offset from the last wafer. A "diamond-shaped" opening should be visible when wafers are properly installed. See the image below for more details.
6. Reinstall the idler assembly.

"Diamond-Shaped Opening"



WARNING: Cancer and Reproductive Harm
www.P65Warnings.ca.gov

MAINTENANCE

(MOTOR REPLACEMENT)

Motor Replacement

In the case of motor failure, perform the following steps to replace the hydraulic motor.

1. Perform the “Maintenance Shutdown Procedure” stated on page 9.
2. Depress the motor mounting pin plungers and pull both pins upwards to unlock the motor from the core lever arm.
3. Use the integrated handles on the motor to pull the motor out of the core.
4. Use an hex wrench to remove the 4 hex head bolts attaching the motor to the motor spacer assembly, remove the upper handle, and the motor.
5. Use an hex key to remove the set screw from the square drive on the motor’s shaft.
6. Carefully slide the square drive off the motor shaft. When the square drive is removed, the motor shaft key will fall out of the retention slot. **DO NOT** lose the motor shaft key. Failure to reinstall the key could result in damage to the attachment.
7. Reinstall the motor shaft key, square drive, and set screw to the new motor. **ALWAYS** add a red thread locker to the square drive set screw.
8. Slide the motor into the motor spacer assembly and install the lower 2 hex bolts to hold it in place.
9. Install the upper handle and the remaining hex bolts.
10. Use the hex wrench to tighten all 4 motor bolts.



WARNING: Cancer
and Reproductive Harm
www.P65Warnings.ca.gov

MAINTENANCE

(IDLER BEARING REPLACEMENT)

Idler Bearing Replacement

In the case of idler bearing failure, perform the following steps to replace the idler bearing.

1. Perform the "Maintenance Shutdown Procedure" found on page 9.
2. Use an hex wrench to loosen the set screw on the idler-bearing lock ring.
3. Use a punch and hammer to turn the idler-bearing lock ring counterclockwise until the ring can be removed.
4. Use an hex wrench to remove the shoulder bolt the idler arm rotates about.
5. Depress the core adjustment pin plunger on the idler-bearing side and remove the pin from the core adjustment arm.
6. Pull the core adjustment arm outwards until it is free.
7. Remove the 4 bolts attaching the idler bearing to the core adjustment arm.
8. Install the new bearing onto the core adjustment arm.
9. Slide the bearing onto the idler shaft and reinstall the shoulder bolt and core adjustment pin.



ALWAYS use threaded locker when reinstalling a shoulder bolt.



Ensure the core adjustment pin detent button is fully extended and locked after pinning the lever arm into position. Failure to lock the core adjustment pins can result in damage to the attachment and possible injury.

10. Slide the idler-bearing lock ring onto the idler shaft and use a hammer and punch to turn the lock ring clockwise until it is tight.
11. Tighten the lock ring set screw.



WARNING: Cancer
and Reproductive Harm
www.P65Warnings.ca.gov

MAINTENANCE

(CUTTING EDGE REPLACEMENT)

Cutting Edge Replacement

The Broce Broom Pickup-Broom Attachments come standard with a double-sided bolt-on cutting edge to double the lifespan of the cutting edge.

When one side of the cutting edge has been worn to a point that warrants replacement, the blade can be removed, rotated 180°, and reinstalled.

After both sides of the bolt-on cutting edge have been worn out, the cutting edge should be replaced.

To replace the bolt-on cutting edge, follow the steps below.

1. Place a platform at least 3" tall (such as a pallet) on the ground to place the attachment. Ensure the platform is where a hoist or other adequate lifting device can access the attachment.
2. Lower the attachment onto the platform, ensuring the cutting edge is not placed on the platform. See the image below.

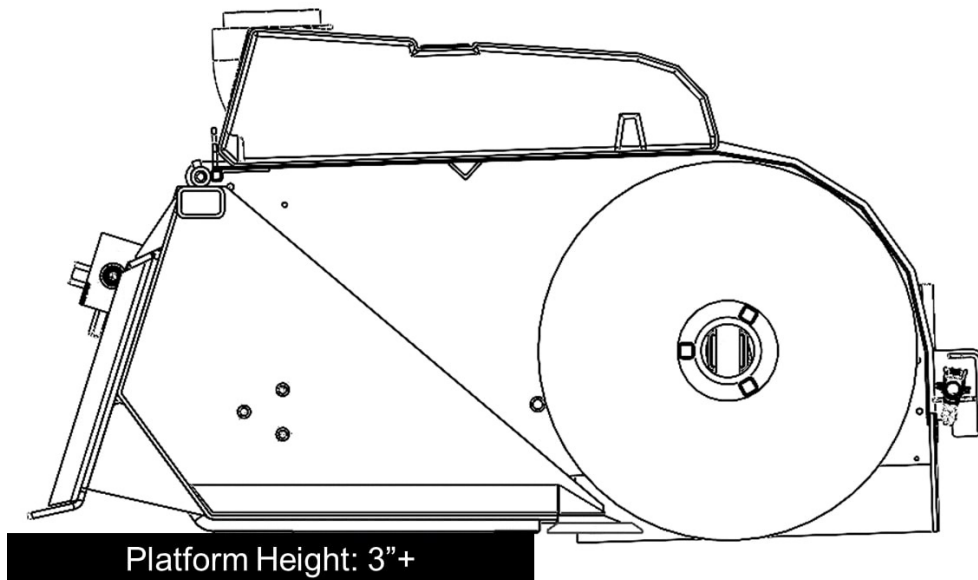

3. Perform steps 2-4 of the "Maintenance Shutdown Procedure" found on page 9.
4. Use a hoist or other adequate lifting device to lift the cover off the bucket's cover stops.



WARNING



Ensure the cover is adequately secured while lifted off the bucket's cover stops. Failure to do so can result in serious injury or death.

5. Use an impact to remove the plow bolt nuts.
6. Reinstall the new cutting-edge and new hardware.



WARNING: Cancer and Reproductive Harm
www.P65Warnings.ca.gov

MAINTENANCE (WATER SYSTEM)

Water System Maintenance

The 40-gallon water system is an optional add-on and requires daily maintenance.

Check water system filters, nozzle screens, and cycle system daily.

Ensure the system is drained during storage or freezing weather.



Failure to drain the water system can result in damage to the system.

To drain the water system, unscrew the strainer cap, allowing water to drain out of the tank.



WARNING: Cancer
and Reproductive Harm
www.P65Warnings.ca.gov

MAINTENANCE (TROUBLESHOOTING)

PROBLEM	PROBABLE CAUSE	SOLUTION
Core motor shaft seal leak	<ol style="list-style-type: none"> 1. String line wrapped around shaft 2. Excessive down pressure (Too much side load) 	<ol style="list-style-type: none"> 1. Remove string line and reseal motor 2. Reseal motor. Instruct operator to use down pressure only when necessary.
Core motor shaft broken	<ol style="list-style-type: none"> 1. Excessive down pressure (Too much side load) 	<ol style="list-style-type: none"> 1. Replace motor. Instruct operator to use down pressure only when necessary.
Brush is Stalled	<ol style="list-style-type: none"> 1. Flow from Skid Steer is Backwards 2. Valve pressure relief set to low 	<ol style="list-style-type: none"> 1. Reverse flow 2. Call customer service for pressure setting



WARNING: Cancer and Reproductive Harm
www.P65Warnings.ca.gov



SERVICE PARTS



WARNING: Cancer
and Reproductive Harm
www.P65Warnings.ca.gov

PARTS (FULL ASSEMBLY BREAK DOWN)

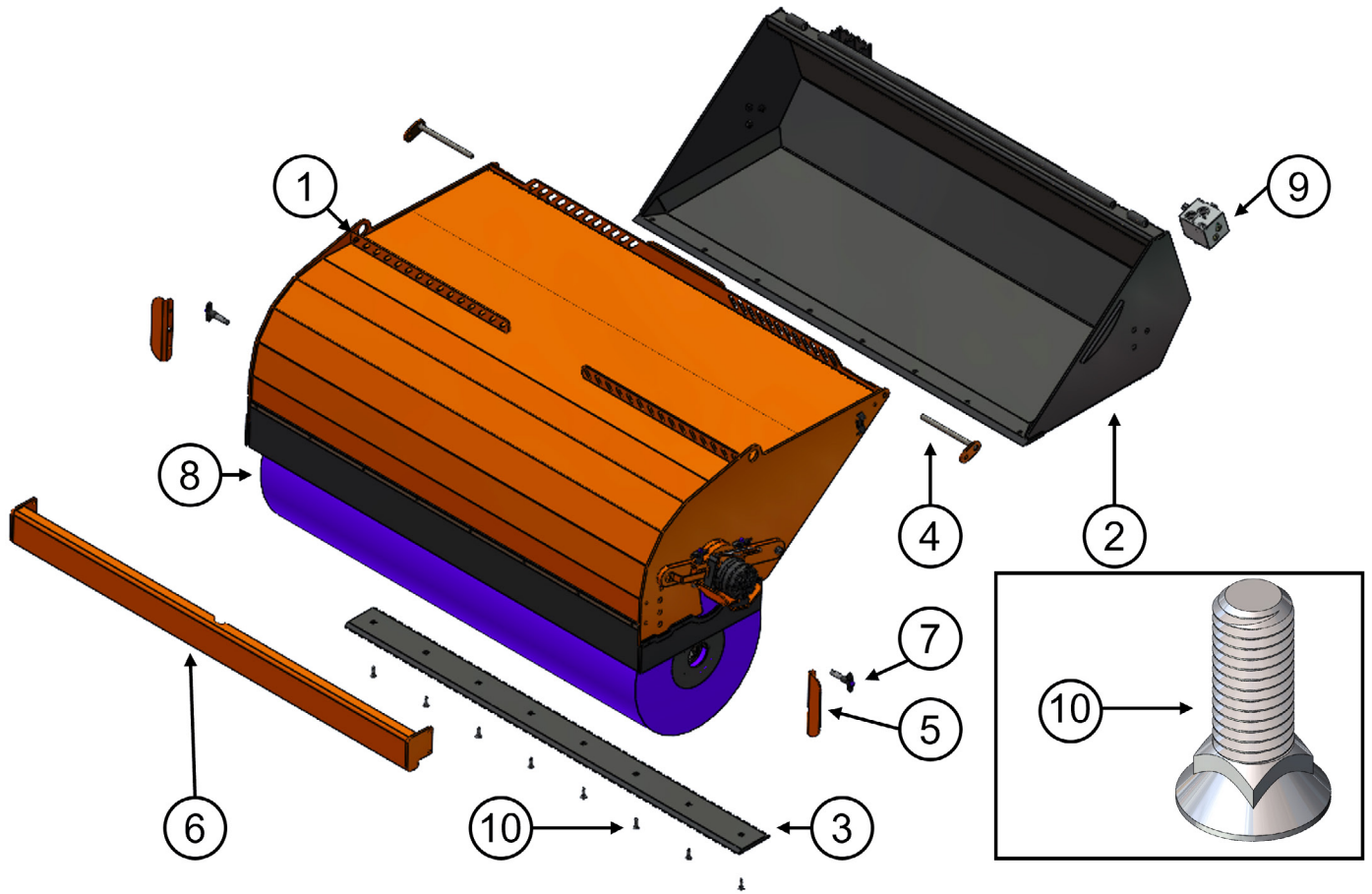

ITEM #	PARTS #	DESCRIPTION	QTY.
1	N/A	See "Cover Assembly"	1
2	391142	72" Straight bend Bucket Assembly	1
3	200530	72" PUB Standard Bolt-on Blade	1
Not Shown	200530C	72" Carbide Bolt-on Blade	Optional
4	391151	Hinge Pin Assembly	2
5	391172	Core Adjustment Pin Guard	2
6	391155	72" PUB Bumper Assembly	1
7	391104	Core Adjustment Pin Guard	2
8		See "Core Assembly"	1
9	391101	Attachment Valve w/o Angle Control	1
10	402504	1.5- 13 x 1.5 Plow Bolt	8



WARNING: Cancer and Reproductive Harm
www.P65Warnings.ca.gov

PARTS (COVER ASSEMBLY)

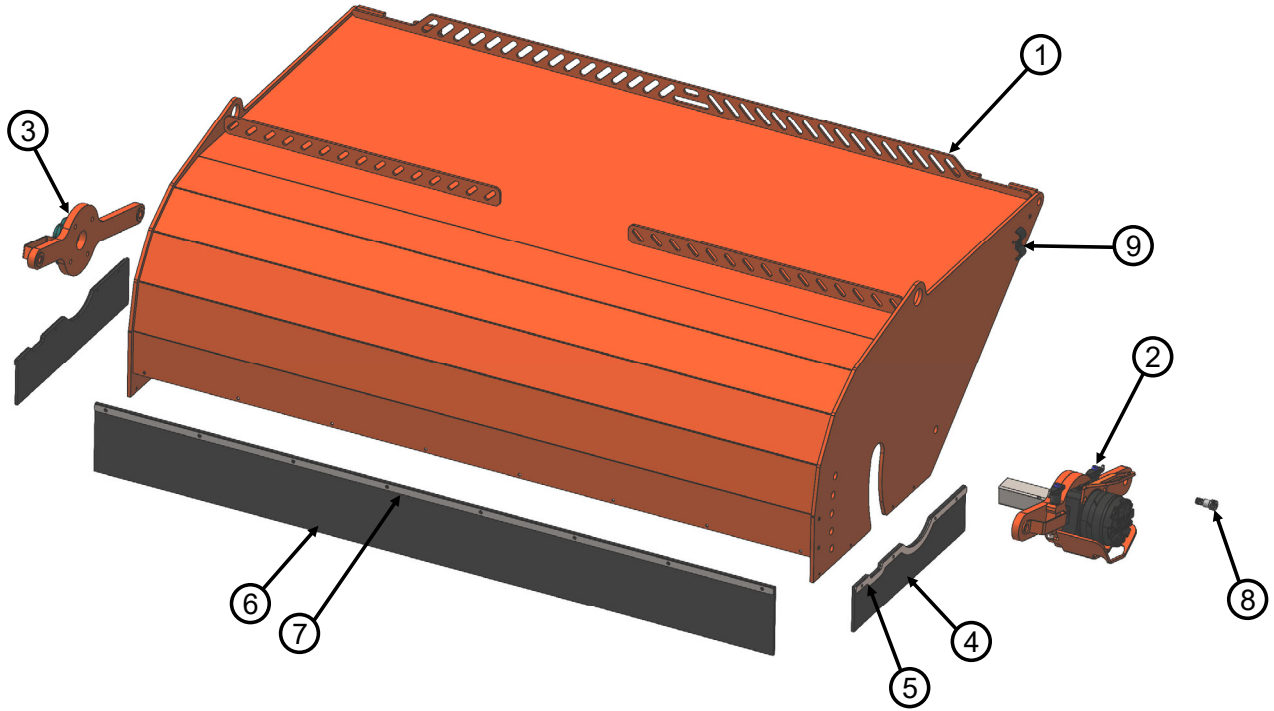

ITEM #	PARTS #	DESCRIPTION	QTY.
1	391118	72" PUB Brush Cover Assembly	1
2	N/A	See "Left-Hand Lever Arm Assembly"	1
3	N/A	See "Right-Hand Lever Arm Assembly"	1
4	391123	PUB Side Rubber	2
5	200532	PUB Side Rubber Plate	2
6	391122	72" PUB Front Rubber	1
7	200531	72" PUB Front Rubber Plate	1
8	402403	Sholder Bolt	2
9	001397	Humpty Clamp	1



WARNING: Cancer
and Reproductive Harm
www.P65Warnings.ca.gov

PARTS (LEFT-HAND LEVER ARM ASSEMBLY)

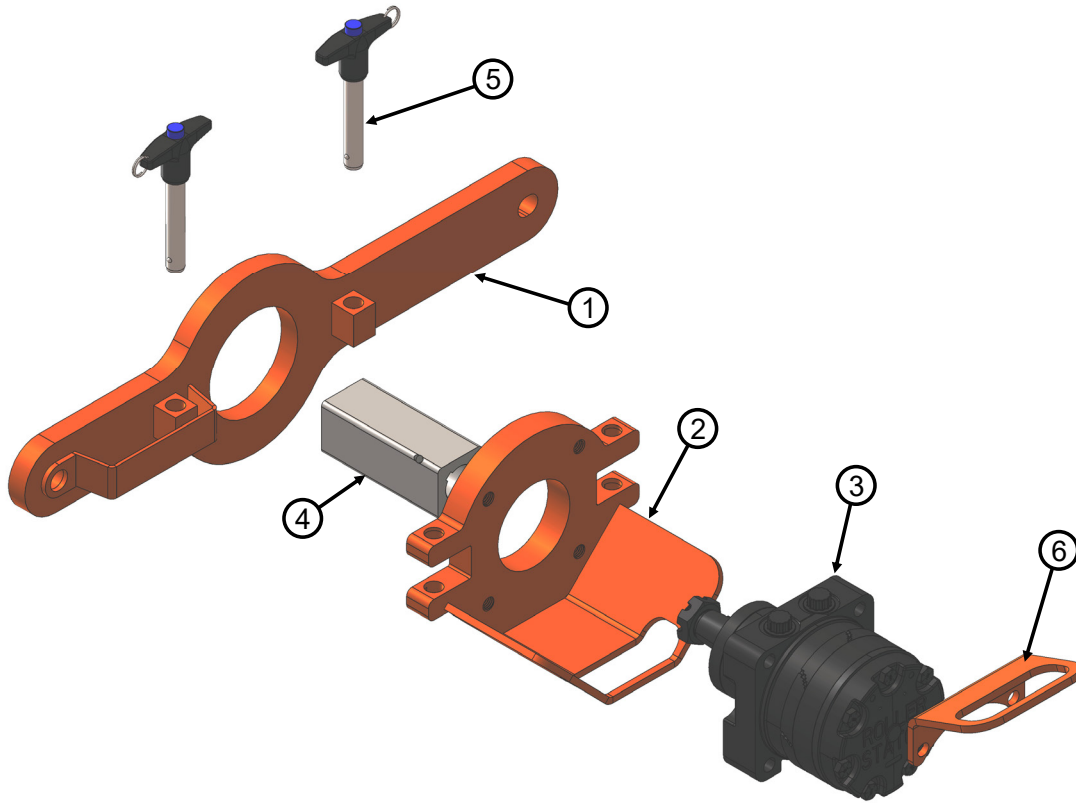

ITEM #	PARTS #	DESCRIPTION	QTY.
1	391148	LH Lever Arm Weldment	1
2	391121	PUB Core Motor Spacer Assembly	1
3	390535	Core Drive Motor	1
4	391108	PUB Square Drive	1
5	391105	PUB Motor Mount Pin	2
6	391156	PUB Motor Handle/Guard	1



WARNING: Cancer and Reproductive Harm
www.P65Warnings.ca.gov

PARTS (RIGHT-HAND LEVER ARM ASSEMBLY)

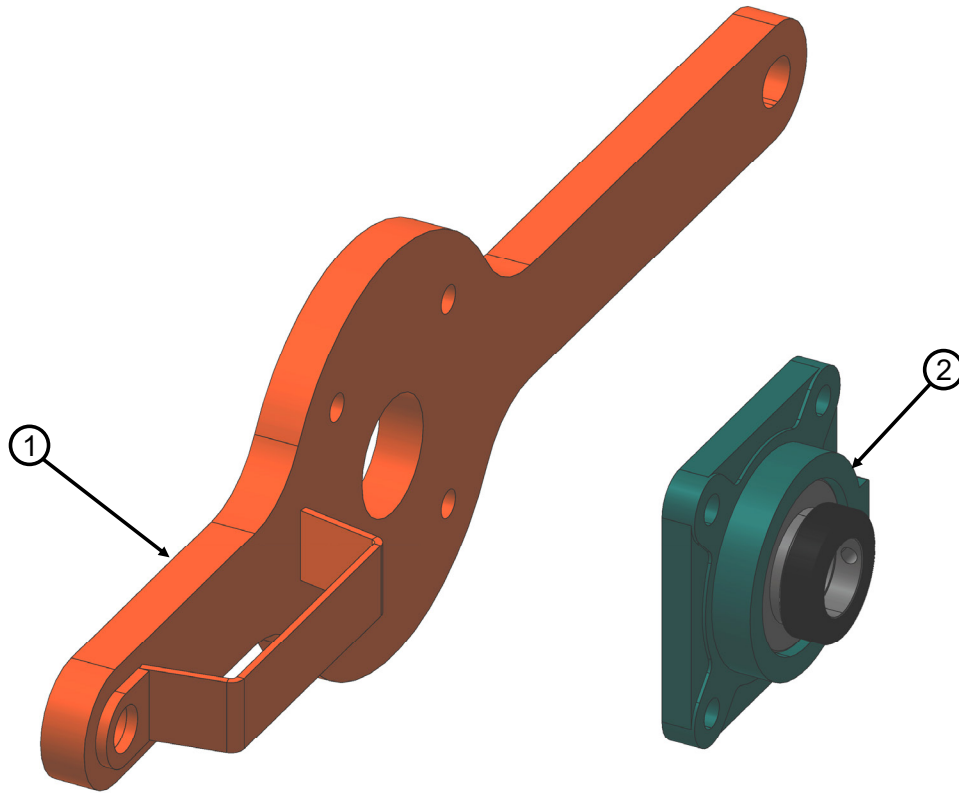

ITEM #	PARTS #	DESCRIPTION	QTY.
1	391145	RH Lever Arm Weldment	1
2	320221	Idler Bearing Assembly	1



WARNING: Cancer
and Reproductive Harm
www.P65Warnings.ca.gov

PARTS (CORE ASSEMBLY)

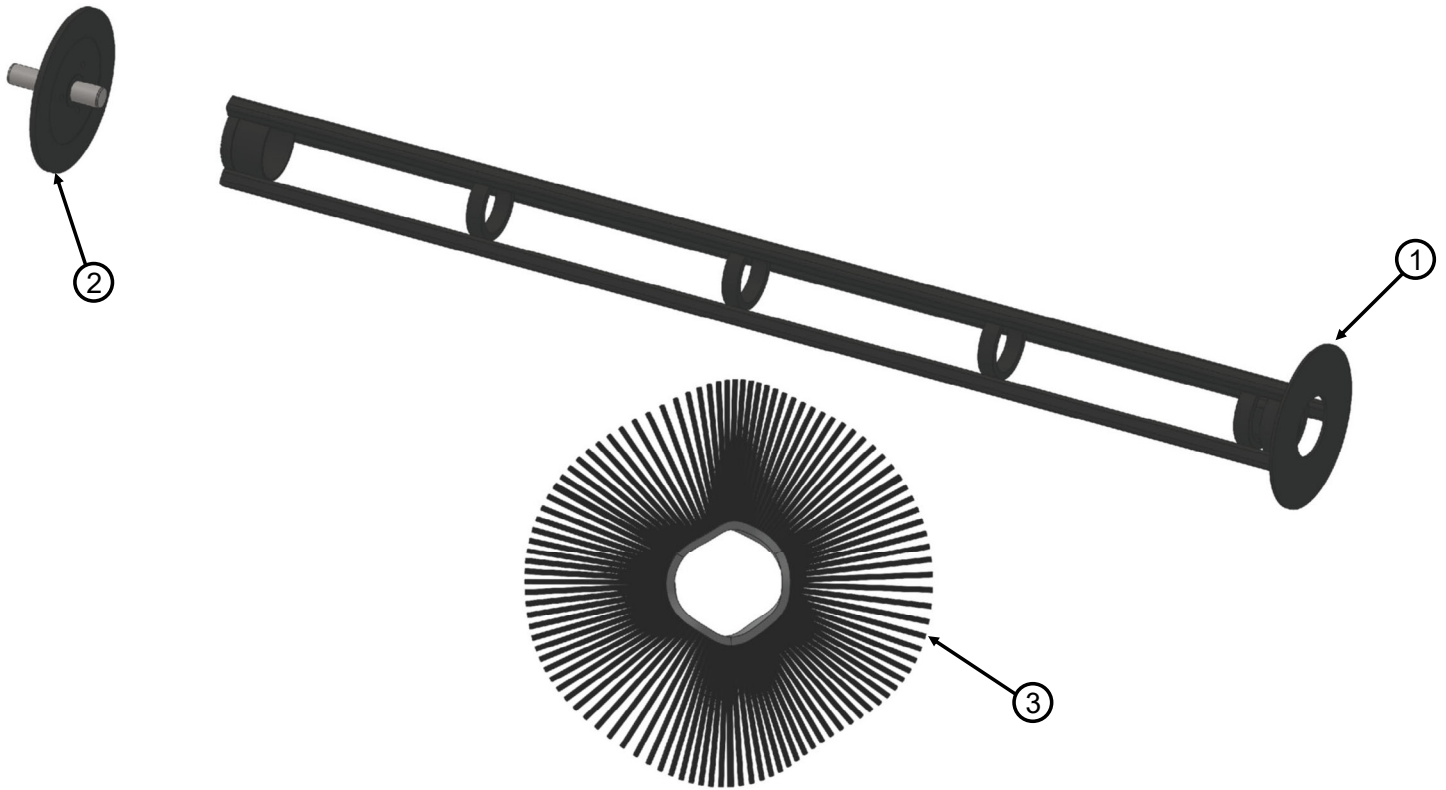

ITEM #	PARTS #	DESCRIPTION	QTY.
1	390620	72" Broom Core	1
2	391157	Idler Bearing Assembly	1
3	200456	24" x 72" Wafer Kit	1



WARNING: Cancer and Reproductive Harm
www.P65Warnings.ca.gov

PARTS (Water System)

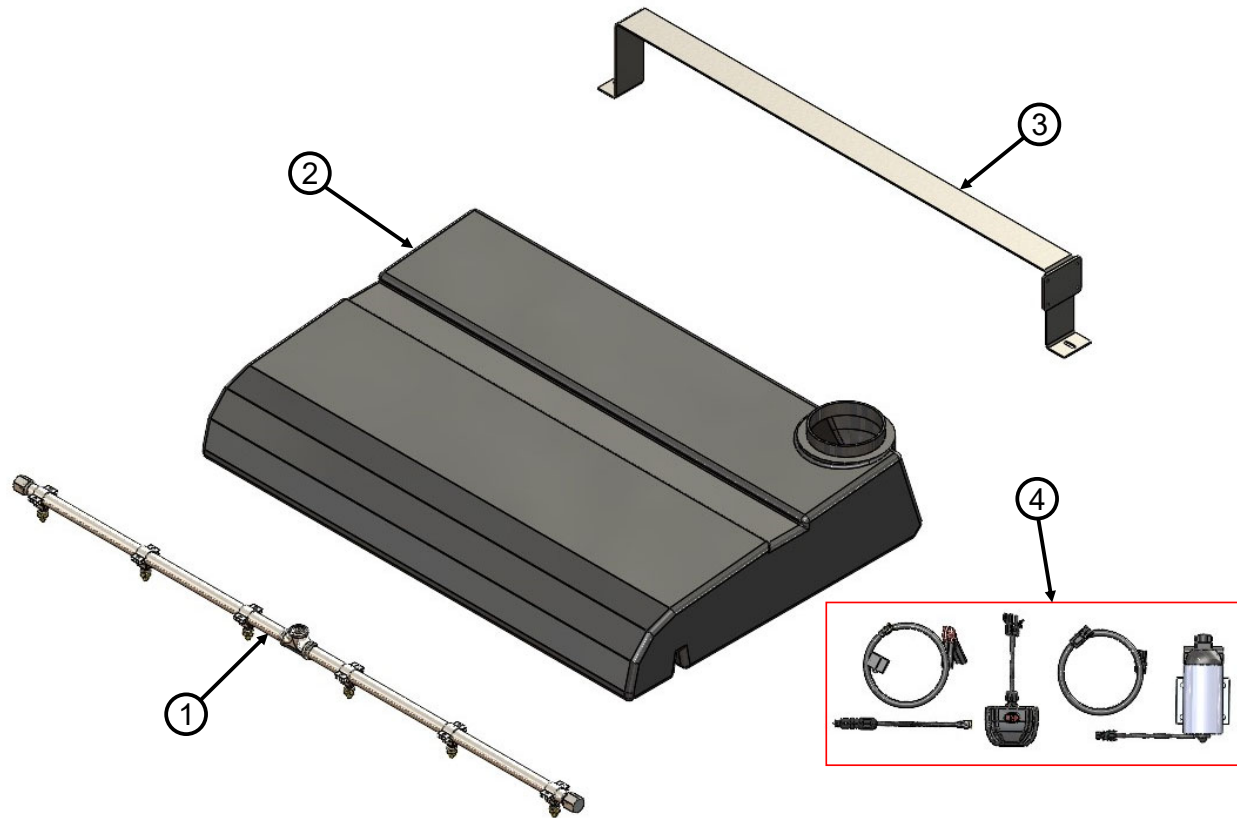

ITEM #	PARTS #	DESCRIPTION	QTY.
N/A	389802	Strainer (not shown)	
N/A	389809	Ball valve (not shown)	
N/A	389808	Check Valve (not shown)	
1	200425	Spray Bar Assembly	1
2	800329	Tank	1
3	800405	Tank Strap	1
4		see "Electrical for Water System"	1
N/A	389799	Fitting, 3/4 NPT TO 1/2 Barb 90 DEG	1
N/A	389798	Fitting, 3/4 NPT TO 1/2 Barb STRAIGHT	2
N/A	389810	Fitting, 1/2 NPT TO 1/2 Barb Striaight	1
N/A	389483	Fitting, 3/8 NPT TO 1/2 Barb	1
N/A	389812	Nipple, 3/4 X 1.5 NPT GALV	1
N/A	389811	Nipple, 3/8 NPT GALV Close STD.	1
N/A	389813	Bushing, 3/4 NPT TO 3/8 NPT	1
N/A	514411	Hose Clamp, SAE 10, 1/2 TO 1-1/16	6
N/A	200407	PUB Water Hose, Tank to Ball Valve	1
N/A	200408	PUB WATER HOSE, PUMP TO CHECK VALVE	1
N/A	200409	PUB Water Hose, Check Valve to Spray Bar	1



WARNING: Cancer and Reproductive Harm
www.P65Warnings.ca.gov

PARTS

(Electrical for Water System)

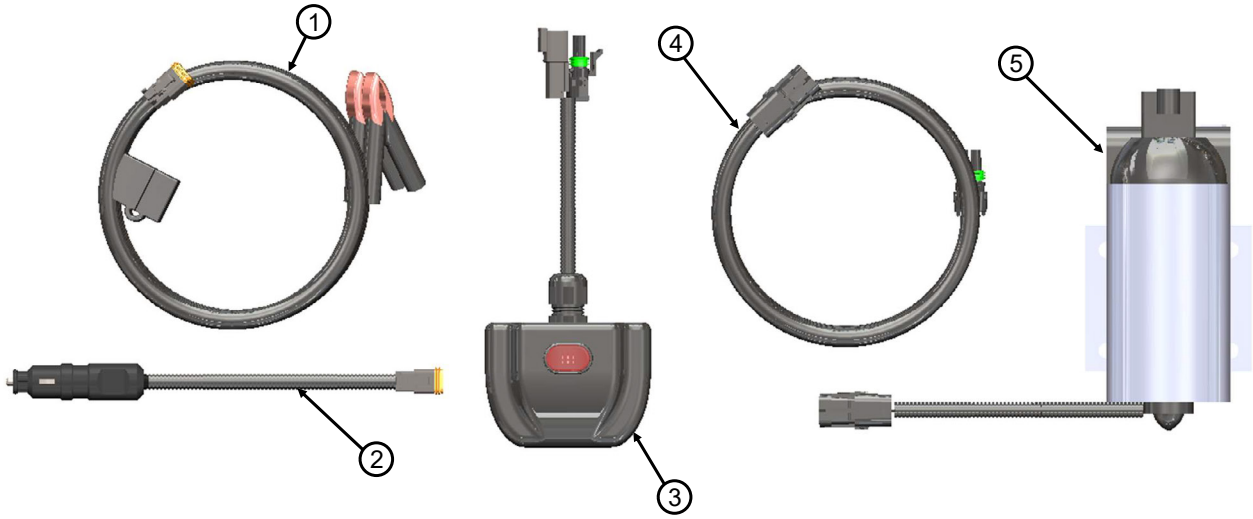

ITEM #	PARTS #	DESCRIPTION	QTY.
1	200430	Power Wire (Battery)	1
2	200432	Power Wire (Cig. Outlet)	1
3	200436	Control Box	1
4	200434	Main Wire	1
5	200433	Water Pump	1



WARNING: Cancer and Reproductive Harm
www.P65Warnings.ca.gov

SCHEMATICS

(Hydraulic Diagram)

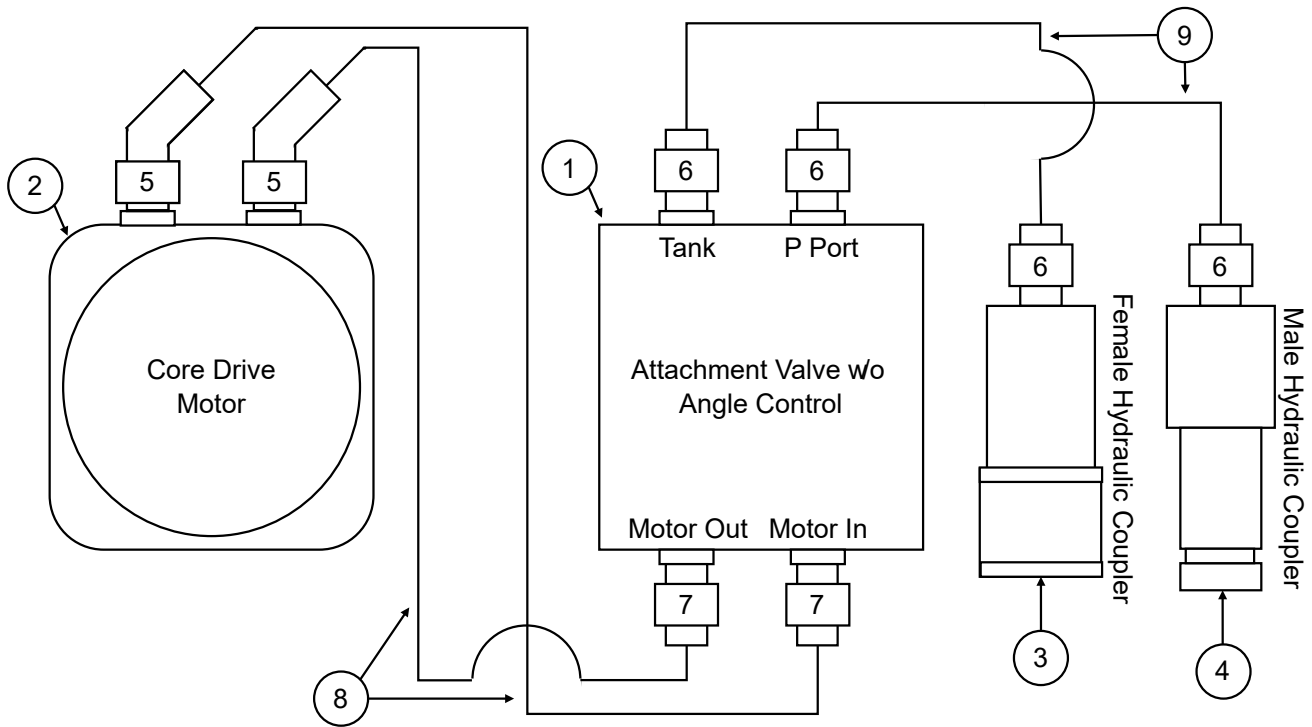

ITEM #	PARTS #	DESCRIPTION	QTY.
1	391101	Attachment Valve w/o Angle Control	1
2	390535	Core Drive Motor	1
3	391107F	Female Hydraulic Coupler	1
4	391107	Male Hydraulic Coupler	1
5	389826	Adapter, 10FS-10ORB 45 deg	2
6	390018	Adapter, 10FS-12ORB STR	2
7	389488	Adapter, 12FS-12ORB STR	5
8	391199	PUB Motor In & Out Hose	2
9	391198	PUB Inlet & Outlet Hose	2
N/A	513310	Adapter, 12 fs - 12 orb 90deg. (not shown)	1
N/A	391180	Stubby Male Hydraulic Coupler (not shown)	1



WARNING: Cancer
and Reproductive Harm
www.P65Warnings.ca.gov

VALVE BREAKDOWN

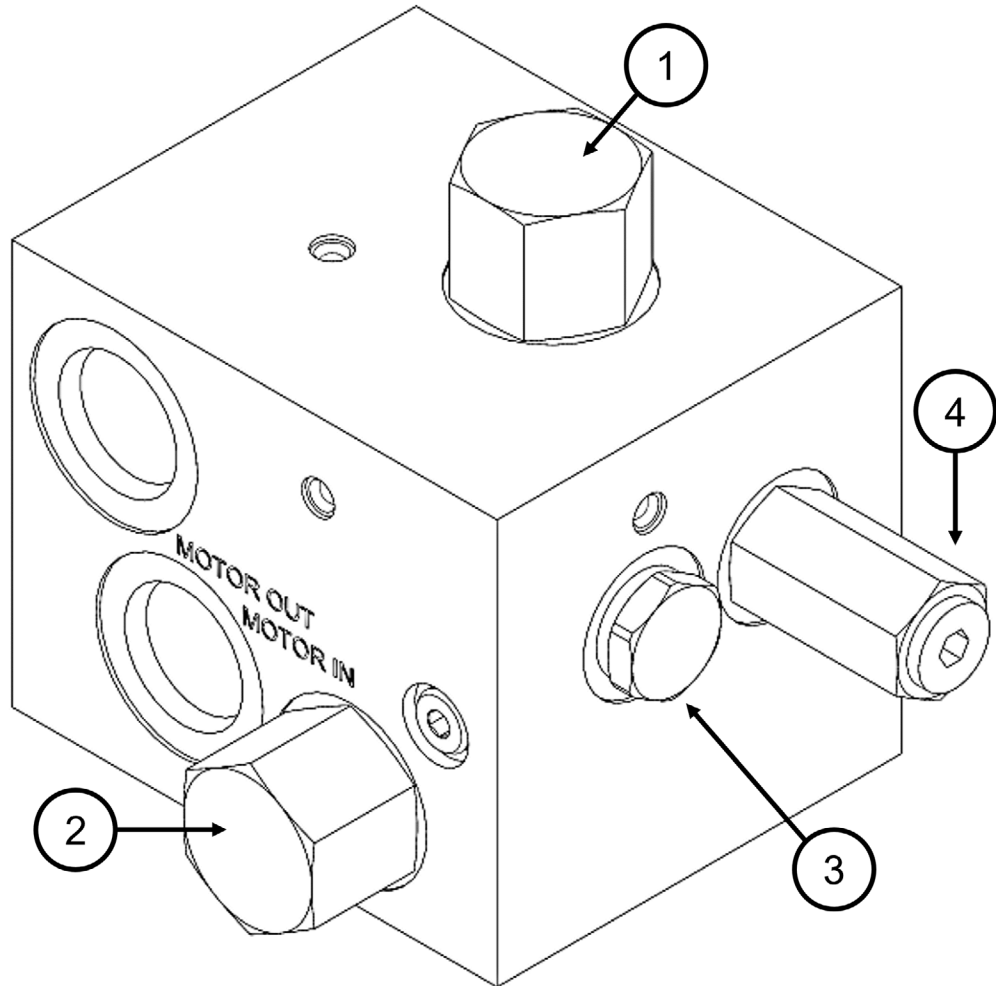

ITEM #	PARTS #	DESCRIPTION	QTY.
1	200555	Logic Element	1
2	200562	Motor Flow Control	1
3	200563	AntiCav Valve	1
4	200264	Relife Valve	1



WARNING: Cancer and Reproductive Harm
www.P65Warnings.ca.gov

DECALS

①

⚠ WARNING
PINCH POINT HAZARD!
Keep hands and feet clear!
Failure to comply could result in death or serious injury.



②

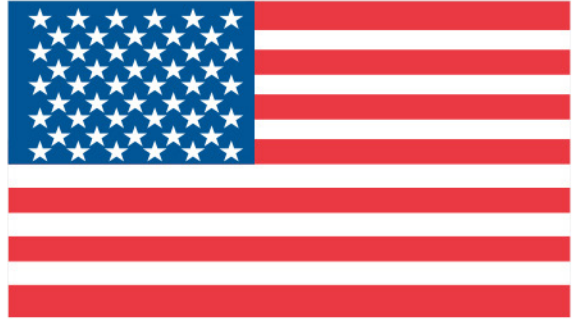

③



WARNING: This product can expose you to chemicals including toluene, carbon black, cumene and ethylbenzene, which is known to the State of California to cause cancer and birth defects or other reproductive harm. For more information, go to: www.P65Warnings.ca.gov

④

Broce Broom

⑤

⚠ WARNING



**FLYING OBJECT HAZARD!
STAY BACK!**
Stay away from discharge area during operation.
Keep others away.
Do not point discharge toward people, animals or property.
Failure to comply could result in death or serious injury.

⑥

⚠ NO RIDERS

⑦

BBA 72P

⑨

COVER RETENTION CHAINS

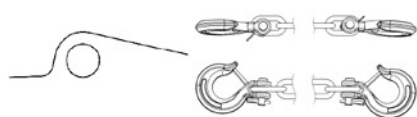

WARNING: Failure to properly adjust the retention chains can result in damage to the attachment. This adjustment must be performed if the skid steer/loader used has changed between adjustments. See manual for proper adjustment procedure.

⑧

BBA 72P
WWW.BROCEBROOM.COM



WARNING: Cancer and Reproductive Harm
www.P65Warnings.ca.gov

DECALS

ITEM #	PARTS #	DESCRIPTION	QTY.
N/S	200486	BBA72P Decal Kit	1
1	200501	Safety Decal - Pinch Point Hazard	2
2	390185	American Flag	1
3	312095	Prop 65	1
4	200365	Swirl Broce Broom Logo Decal	2
5	200506	Safety Decal - Flying Objects	2
6	443581	No Riders	2
7	200378	BBA72P Front Logo Decal	2
8	200379	BBA72P Side Logo Decal	2
9	200505	Cover Retention Chain Decal	2



WARNING: Cancer
and Reproductive Harm
www.P65Warnings.ca.gov

SERVICE PARTS TO STOCK

DESCRIPTION
Bolt on blade
Bumper
Motor
Motor spacer assy
Pin guards
Idler bearing
24" wafers
Core adjustment pin
Motor mounting pin
Front and side rubber skirts



WARNING: Cancer
and Reproductive Harm
www.P65Warnings.ca.gov



**CALIFORNIA
Proposition 65 Warning**

Diesel engine exhaust and some of its constituents are known to the State of California to cause cancer, birth defects, and other reproductive harm.
For more information, visit: www.P65Warnings.ca.gov

WARNING: Battery posts, terminal and related accessories contain lead and lead compounds, chemicals known to the State of California to cause cancer, birth defects, and other reproductive harm. Wash hands after handling.
For more information, visit: www.P65Warnings.ca.gov

Broce Manufacturing Co. Inc. - 1460 South 2nd Avenue - Dodge City, KS 67801
(877) 227-8811 - FAX (620) 227-3012 - parts@brocebroom.com
M-F 7:00 AM-6:00 PM CST

1-866-283-2759

www.brocebroom.com